

Electric Gripper Solutions

phd [®]
PLUS
Electric Automation Solutions

Series EGRR Electric High Capacity Gripper

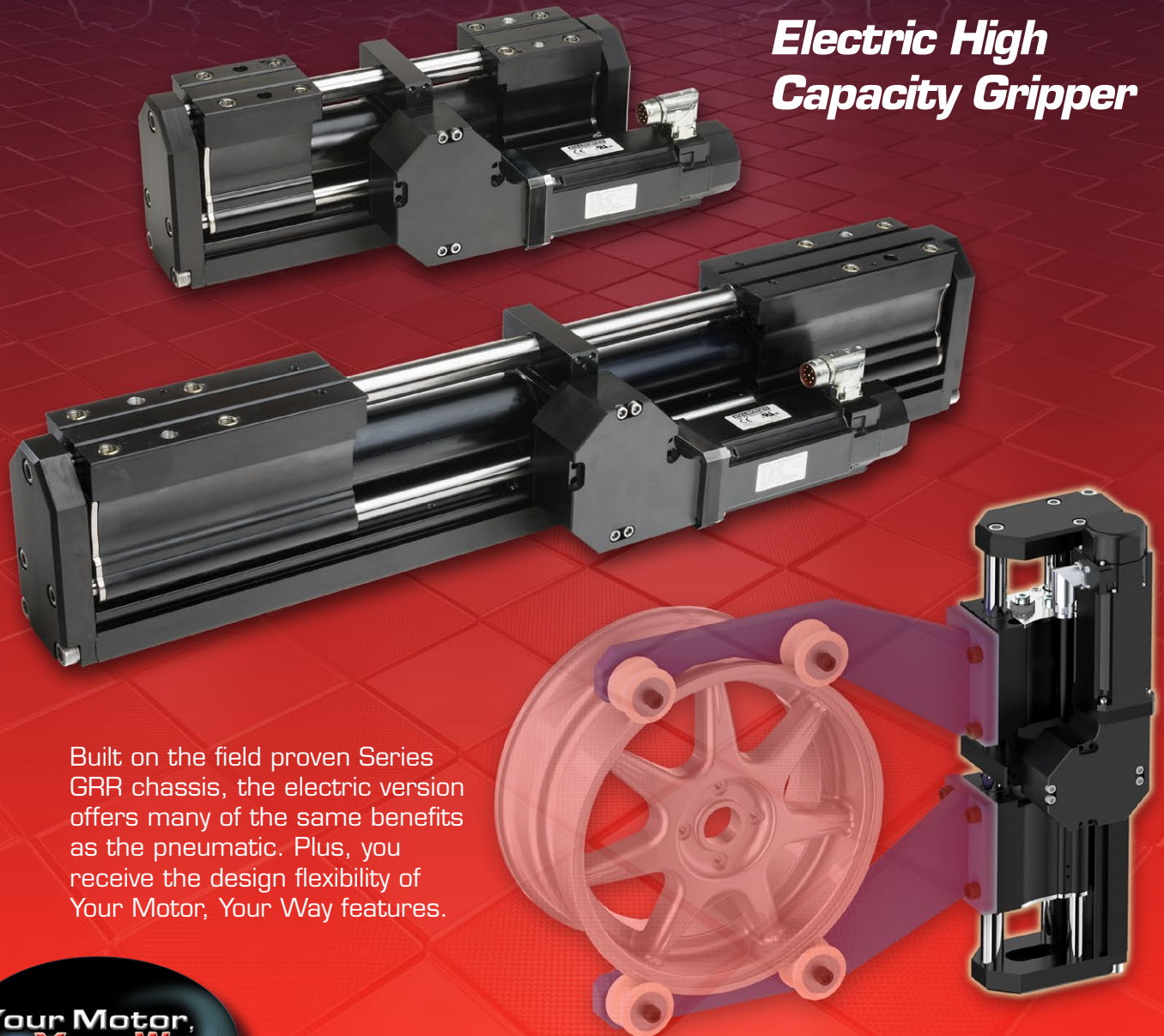

Built on the field proven Series GRR chassis, the electric version offers many of the same benefits as the pneumatic. Plus, you receive the design flexibility of Your Motor, Your Way features.

**Your Motor,
Your Way**

**ISO 9001
REGISTERED**
Quality Management
System Certified

EGRR01A

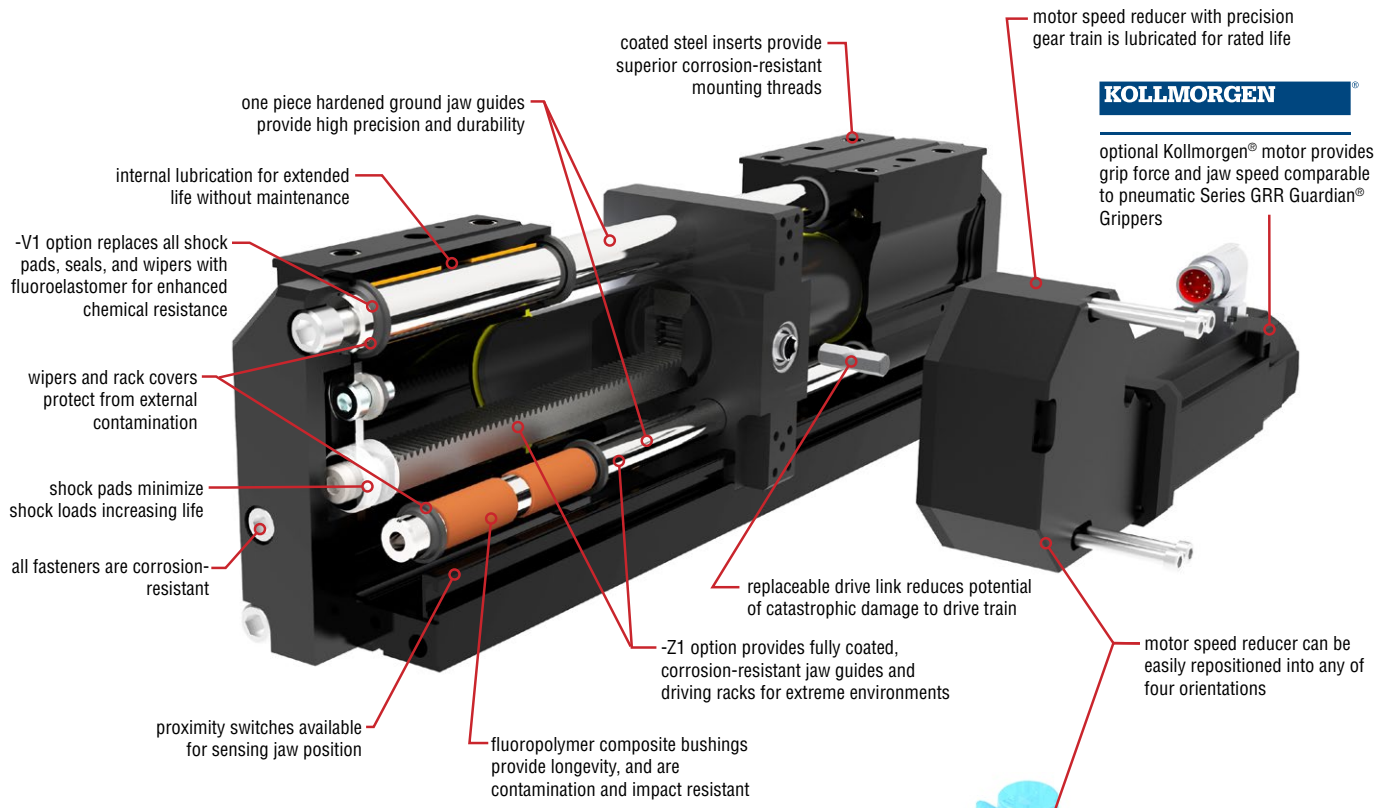

Major Benefits

- Servomotor control provides acceleration, velocity, and position feedback.
- Compact design provides high grip force, large moment capacities, long jaw travel, and low overall weight for applications with limited space.
- Rugged construction withstands high impact and shock loads in demanding industrial environments.
- Three large diameter jaw guides spanning the length of the gripper provide stable jaw travel, long allowable tooling length, and high moment capacities.
- Robust rack and pinion jaw drive provides repeatable jaw positioning.
- **Your Motor, Your Way** allows motor and controls flexibility at no additional cost.
- Optional PHD-supplied Kollmorgen® motor matches performance of popular pneumatic Series GRR Guardian® Gripper.

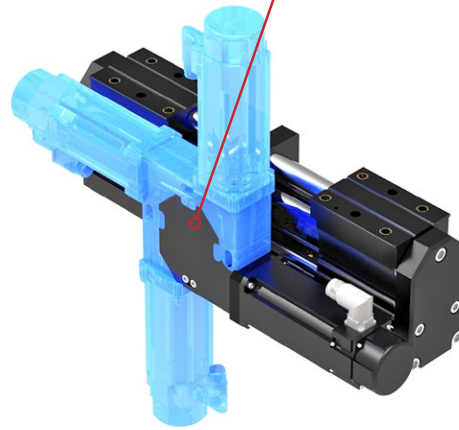

ORDERING DATA: SERIES EGRR ELECTRIC HIGH CAPACITY GRIPPER

Example Ordering Data:

E	G	R	R	1	2	-	5	-	63	x	200	-	V1-Z1	-	RW151	-	Wxxxx	-	Mxxxx
Electromechanical	Gripper	Regular Duty	Long Travel, High Capacity Parallel Gripper	Synchronized, Standard Grip	Jaw Style 2		Design No. 5 - Metric 1 - Imperial See Note		Size		Jaw Travel mm in 150 5.906 200 7.874 250 9.843 300 11.811 350 13.780 (Home positioning may reduce usable travel)		Options V1 - Fluoroelastomer seals and wipers Z1 - Fully corrosion-resistant coating on jaw guides and drive racks. NOTE: Fasteners are corrosion resistant as standard		15:1 Motor Speed Reducer		Motor Mounting Code W0174 - Direct mounting for Kollmorgen® AKM33H-AN92CA00 Wxxxx - Open architecture part number code (configure code online) W0000 - Blank Motor Mounting		Motor Code (requires RW151-W0174) M1095 - PHD-supplied Kollmorgen® AKM33H-AN92CA00 (performance comparable to PHD Series GRR Gripper) No Code - No Motor

Options must be ordered together

NOTE: Design Number dictates imperial or metric mountings. Dowel pin holes are metric regardless of design number.

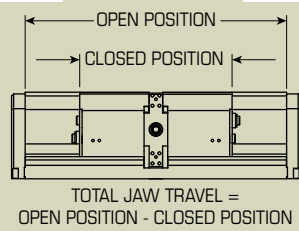

MOUNTING OPTIONS & ACCESSORIES

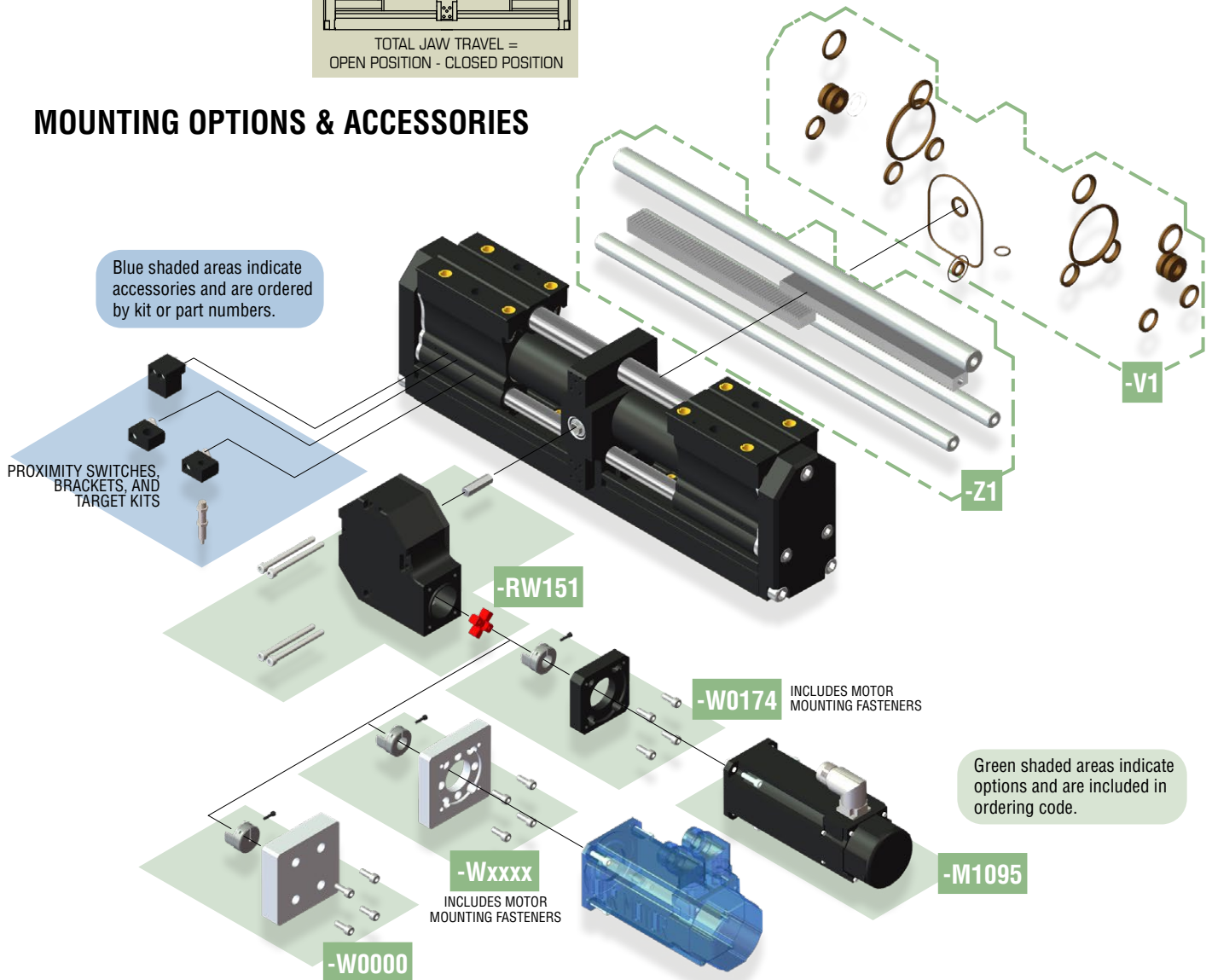

ENGINEERING DATA: SERIES EGRR ELECTRIC HIGH CAPACITY GRIPPER

SPECIFICATIONS		SERIES EGRR
INPUT TORQUE	Without Motor Speed Reducer	2.9 Nm min to 43.2 Nm max [26 in-lb min to 382 in-lb max]
	With RW151 Motor Speed Reducer	0.3 Nm min to 3.8 Nm max [2.3 in-lb min to 34 in-lb max]
INPUT RUNNING SPEED	Without Motor Speed Reducer	400 rpm max
	With RW151 Motor Speed Reducer	6000 rpm max
JAW GRIP SPEED*		50 mm/sec max [2 in/s max]
OPERATING TEMPERATURE		-28° to +82° C [-20° to 180° F]
RATED LIFE		5 million cycles minimum
GRIP REPEATABILITY		Within 0.05 mm [.002 inch] of original centered position
LUBRICATION		Factory lubricated for rated life
MAINTENANCE		Field repairable (except reducer)

* Jaw grip speed is speed which jaws contact gripped workpiece. Jaws may operate at faster speeds, but must decelerate to grip speed prior to grip.

MODEL NUMBER	TOTAL JAW TRAVEL		GRIPPER WEIGHT						FULL TRAVERSE TIME FACTOR**	GRIP FORCE FACTOR G_f^*	
	TRAVEL TOLERANCE		WITHOUT MOTOR SPEED REDUCER		WITH MOTOR SPEED REDUCER		WITH REDUCER & M1095 MOTOR			METRIC	IMPERIAL
	+4.8 +2.1	+ 0.189 + 0.084	kg	lb	kg	lb	kg	lb	C_f		
EGRR12-x-63 x 150	150	5.906	12.8	28.2	14.9	32.8	18.3	40.2	1057	937	23.8
EGRR12-x-63 x 200	200	7.874	15.3	33.7	17.4	38.3	20.8	45.7	1410		
EGRR12-x-63 x 250	250	9.843	18.2	40.1	20.3	44.7	23.7	52.1	1762		
EGRR12-x-63 x 300	300	11.811	20.5	45.1	22.5	49.7	25.9	57.1	2115		
EGRR12-x-63 x 350	350	13.780	22.7	50.1	24.8	54.7	28.2	62.1	2467		

* Grip force varies with tooling length

**Time factors assume a total jaw acceleration and deceleration of 1G (0.5 G per jaw) to and from jaw running speed

MODEL NUMBER	JAW TRAVEL FACTOR J_T				JAW TRAVEL DIRECTION			
	WITHOUT MOTOR SPEED REDUCER		WITH RW151 MOTOR SPEED REDUCER		WITHOUT MOTOR SPEED REDUCER		WITH RW151 MOTOR SPEED REDUCER	
	METRIC	IMPERIAL	METRIC	IMPERIAL	CW	CCW	CW	CCW
EGRR12-x-63 x 150	127.674	5.027	8.512	0.335	Open	Close	Close	Open
EGRR12-x-63 x 200								
EGRR12-x-63 x 250								
EGRR12-x-63 x 300								
EGRR12-x-63 x 350								

MAXIMUM ALLOWABLE FORCES AND MOMENTS

MODEL NUMBER	F_a		M_x		M_y		M_z	
	N	lb	Nm	in-lb	Nm	in-lb	Nm	in-lb
EGRR12-x-63 x 150	15570	3500	880	8000	715	6500	715	6500
EGRR12-x-63 x 200	15570	3500	990	9000	825	7500	825	7500
EGRR12-x-63 x 250	15570	3500	990	9000	825	7500	825	7500
EGRR12-x-63 x 300	15570	3500	990	9000	825	7500	825	7500
EGRR12-x-63 x 350	15570	3500	990	9000	825	7500	825	7500

F_a: Total for both jaws

M_x: Allowable moment per jaw, measured from jaw mounting surface

M_y: Allowable moment per jaw, measured from geometric center of jaw

M_z: Allowable moment per jaw, measured from jaw mounting surface

When calculating the value for F_a , include weight of tooling, part weight, acceleration, and external forces. When calculating values for M_x , M_y , and M_z , include the grip force per jaw, part weight, external forces, and acceleration as applicable.

! MOMENT VALUES ASSUME THE USE OF ALL THREADED MOUNTING HOLES.

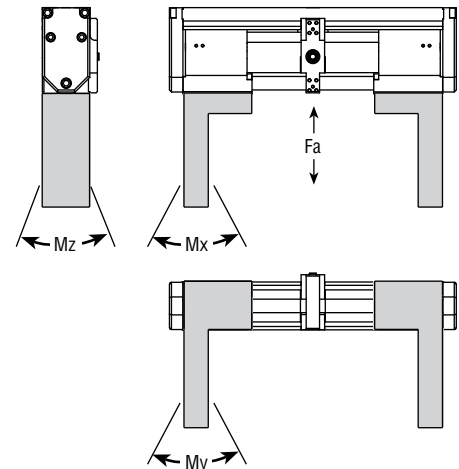

GRIP FORCE

Total gripping force relative to tooling length is shown below at the stated torque applied to the motor speed reducer input shaft. Grip force per jaw equals the total grip force divided by two. The graphs also indicate the maximum tooling length and maximum rated grip force for each gripper size.

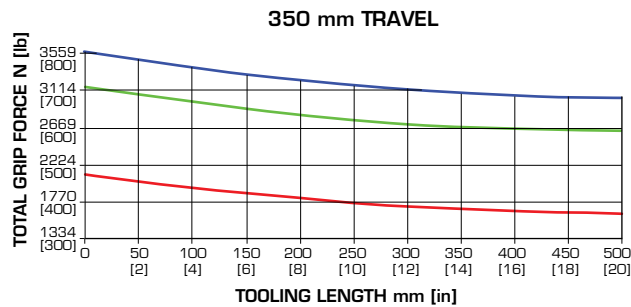
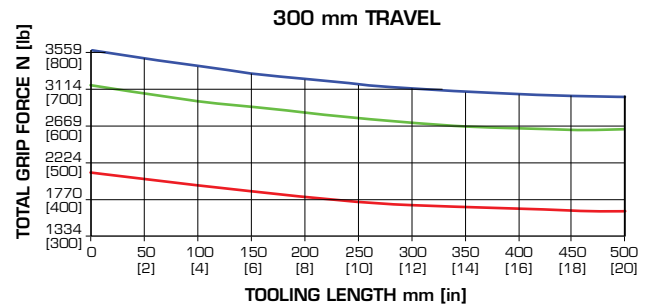
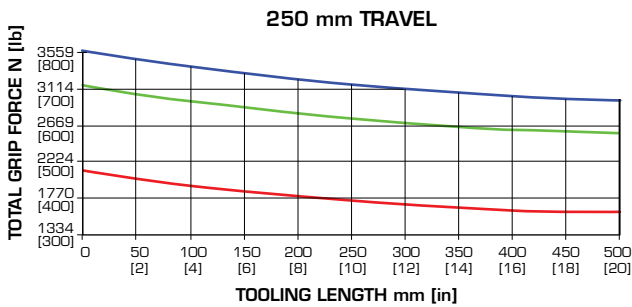
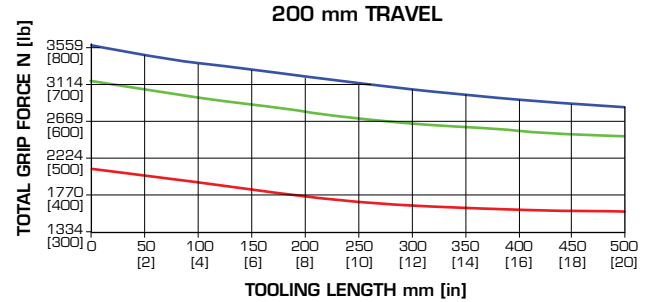
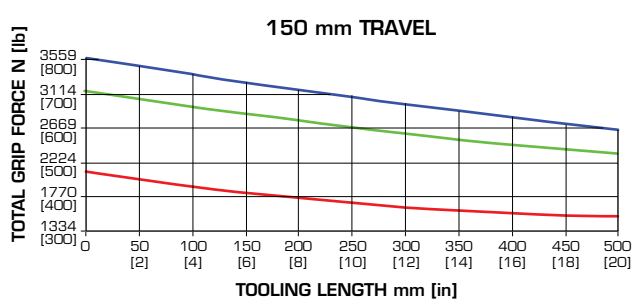
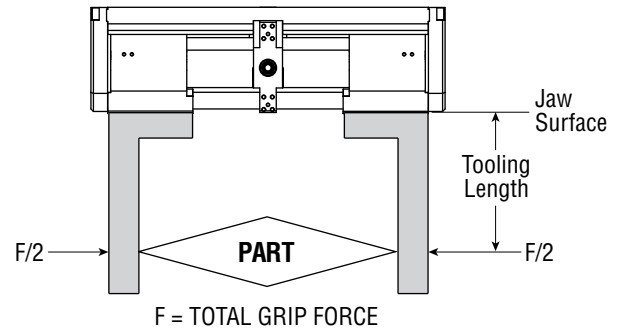
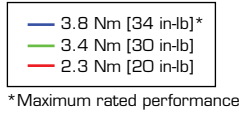

TOOLING LENGTH FACTOR

Jaw tooling should be designed so that the grip point is as close to the jaw surface as possible. As the grip point is moved away from the jaw surface, the applied moment causes jaw friction to increase, resulting in reduced effective grip force. The grip force factor (G_f) values given in the table are for zero tooling length (jaw surface).

The maximum load that grippers can handle will vary based on: size of the part being picked up, shape of the part, texture of the part, speed at which the part is transferred, shape of the fingers, etc. PHD recommends that the fingers of jaws be tooled or machined to conform to the shape of the part being gripped.

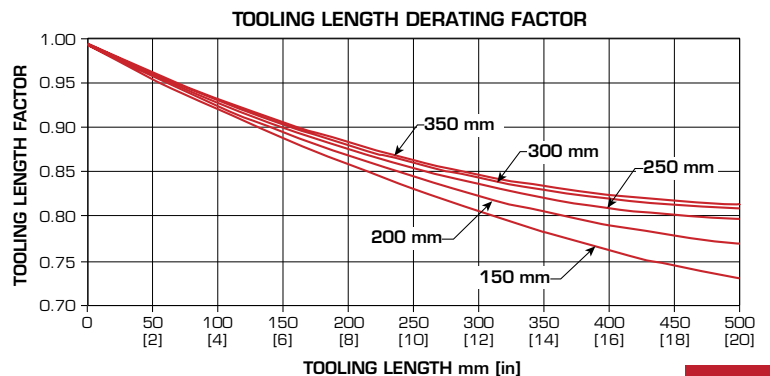

GRIP FORCE EQUATIONS:

METRIC: TOTAL GRIP FORCE (N) = (Torque [Nm] x G_F) x Tooling Length Factor

IMPERIAL: TOTAL GRIP FORCE (lb) = (Torque [in-lb] x G_F) x Tooling Length Factor

GRIP FORCE CALCULATION EXAMPLE:

Gripper: Series EGRR Size 63 x 200

Common Parameters:

Input Torque = 3.4 Nm [30 in-lb]

Tooling Length = 254 mm [10 in]

- Determine Grip Force Factor G_F** = 937 [23.8] (from table on page 4)
- Determine Tooling Length Factor** = 0.84 [0.84] (from Tooling Length Factor graph on page 5)
- Total Grip Force Calculations:**
For Standard Unit: EGRR12-5-63 x 200 [EGRR12-1-63 x 200]
Total Grip Force = 3.4 Nm x 937 x 0.84 = 2676 N [30 in-lb x 23.8 x 0.84 = 600 lb]

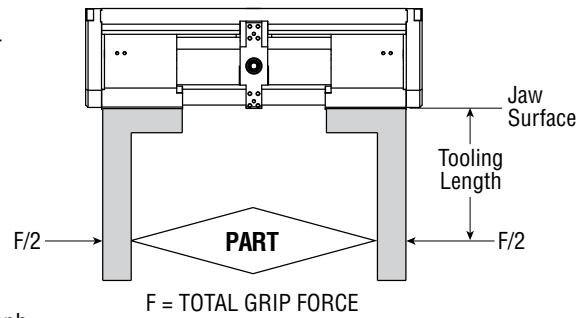

FULL TRAVERSE TIME

Full traverse time is the shortest time possible for the jaws to completely traverse the total travel of the gripper. Use PHD Sizing Software to calculate the motion time for your specific motion profile. Full traverse time assumes that the jaws are accelerated at 1 G (0.5 G per jaw) up to the motor running speed, then travel at the motor running speed until decelerated at 1 G (0.5 G per jaw) to rest.

FULL TRAVERSE TIME EQUATION:

TIME (sec) = $[C_F1 \div \text{Running Speed (rpm)}] + [\text{Running Speed (rpm)} \div 69120]$

FULL TRAVERSE TIME CALCULATION EXAMPLE:

Gripper: Series EGRR Size 63 x 200

Common Parameters:

Motor Running Speed = 5500 rpm

- Determine Time Factors:**
 C_F = 1410 (from table on page 4)
- Release Time Calculations:**
For Standard Unit: EGRR12-5-63 x 200 [EGRR12-1-63 x 200]
Open or Close Time = $[1410 \div 5500 \text{ rpm}] + [5500 \text{ rpm} \div 69120] = 0.336 \text{ sec}$

JAW TRAVEL EQUATIONS:

The jaw travel equation relates the rotation of the gripper or motor speed reducer input shaft to the linear travel of the jaws.

METRIC: TOTAL JAW TRAVEL (mm) = Input Shaft Rotation (rev) x J_T

IMPERIAL: TOTAL JAW TRAVEL (in) = Input Shaft Rotation (rev) x J_T

JAW TRAVEL CALCULATION EXAMPLE:

Gripper: Series EGRR Size 63 x 200 -RW151 -W0000

Common Parameters:

Motor Rotation = 2 rev

- Determine Jaw Travel Factor J_T** = 8.512 [0.335] (from table on page 4)
- Jaw Travel Calculations:**
For Standard Unit: EGRR12-5-63 x 200 -RW151 -W0000 [EGRR12-1-63 x 200 -RW151 -W0000]
Total Jaw Travel = 2 rev x 8.512 = 17.024 mm [2 rev x 0.335 = 0.670 in]

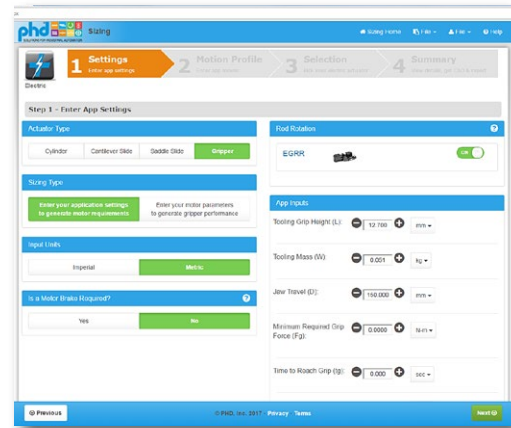
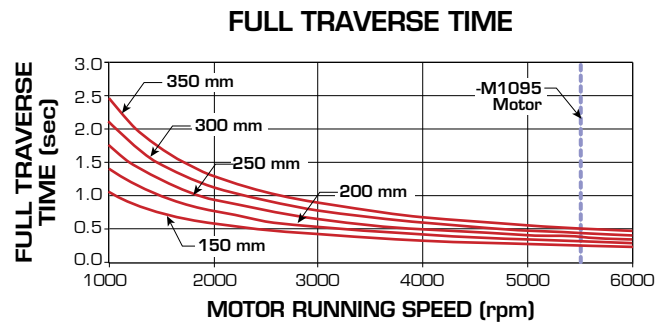

Series EGRR Sizing Software

Engineering requirements, concept and detail design

phdinc.com/sizing



DIMENSIONS: SERIES EGRR ELECTRIC HIGH CAPACITY GRIPPER

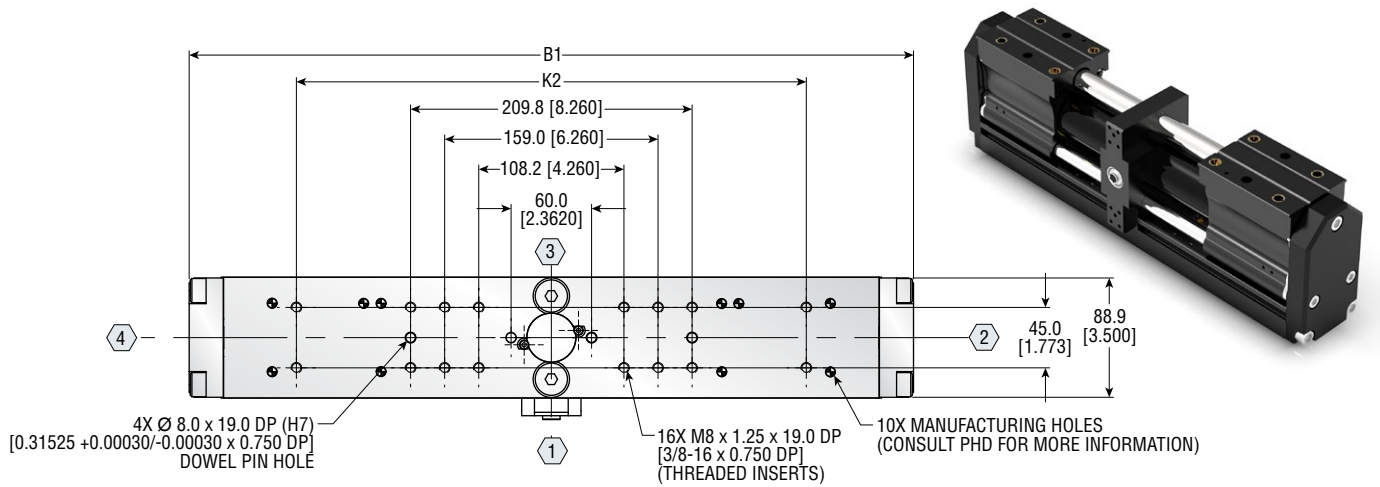

⚠ MOMENT CAPABILITY REQUIRES USE OF ALL THREADED MOUNTING HOLES

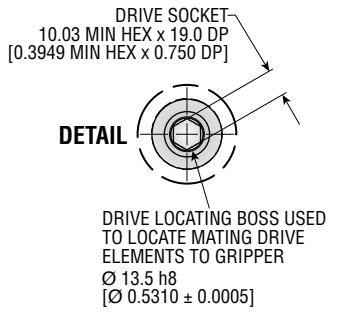
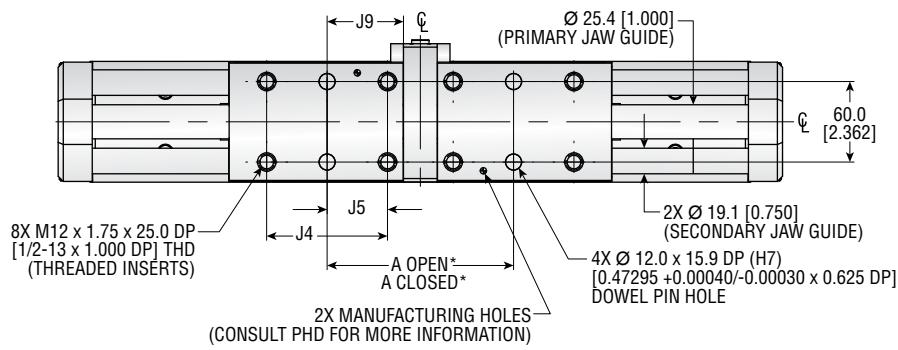
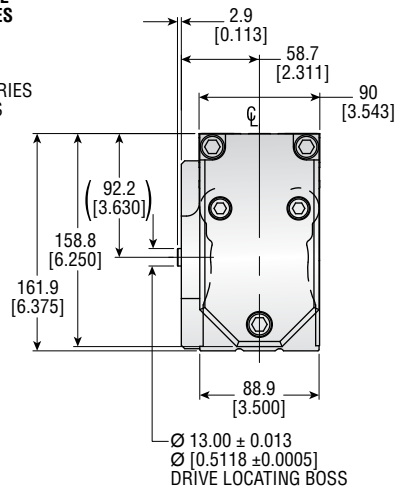
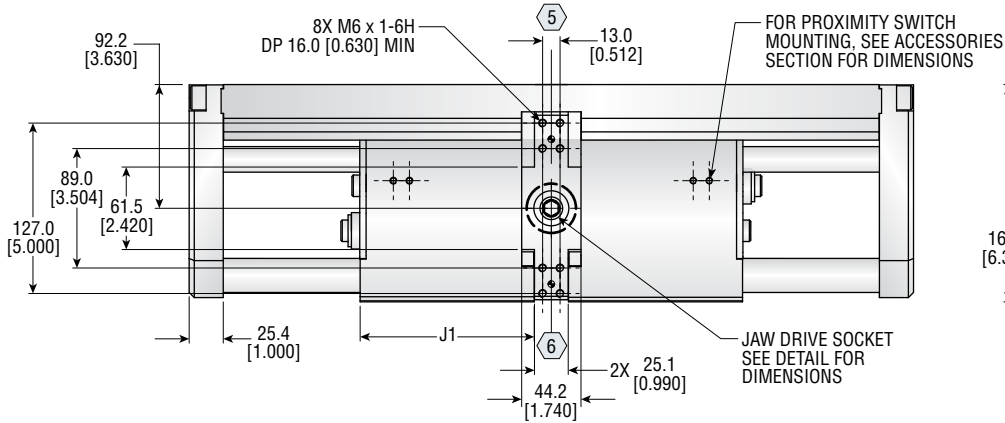

LETTER DIM	TOTAL JAW TRAVEL									
	150		200		250		300		350	
	mm	in	mm	in	mm	in	mm	in	mm	in
MIN. TRAVEL PER JAW	75.0	2.953	100.0	3.937	125.0	4.921	150.0	5.906	175.0	6.890
A CLOSED *	120.0	4.724	139.8	5.504	139.8	5.504	280.0	11.024	330.0	12.992
A OPEN *	270.0	10.630	339.8	13.379	389.8	15.347	580.0	22.835	680.0	26.772
B1	439.8	17.314	539.8	21.251	660.8	26.016	760.8	29.953	860.8	33.890
J1	105.1	4.136	130.0	5.120	165.6	6.518	190.6	7.504	215.6	8.487
J4	66.0	2.598	90.0	3.544	90.0	3.544	90.0	3.544	90.0	3.544
J5	33.0	1.299	45.0	1.772	45.0	1.772	45.0	1.772	45.0	1.772
J9	47.0	1.850	56.9	2.240	56.9	2.240	127.0	5.000	152.0	5.984
K2	320.0	12.598	380.0	14.960	380.0	14.960	590.0	23.228	590.0	23.228

- NOTES:**
- 1) DESIGNATED ϕ IS CENTERLINE OF UNIT
 - 2) ALL DIMENSIONS ARE REFERENCE ONLY UNLESS SPECIFICALLY TOLERANCED
 - 3) IMPERIAL INFORMATION SHOWN IN [] OR SHOWN IN COLUMNS DESIGNATED IN
 - 4) NUMBERS IN \square INDICATE POSITIONS
 - 5) *A OPEN REFLECTS THE SMALLEST POSSIBLE OPEN DIMENSION
*A CLOSED REFLECTS THE LARGEST POSSIBLE CLOSED DIMENSION

OPTIONS: SERIES EGRR ELECTRIC HIGH CAPACITY GRIPPER

Z1 CORROSION-RESISTANT

Corrosion-resistant coating on jaw guides and drive racks provides enhanced environmental protection.

V1 FLUORO-ELASTOMER SEALS

Fluoro-elastomer shock pads, seals, and wipers are available to achieve material compatibility with certain fluids. Material compatibility should be checked with the fluid manufacturer for proper application. This option includes Series GRR -V9 fluoro-elastomer seals and jaw guide wipers option.

RW151 MOTOR SPEED REDUCER

A 15:1 drive ratio motor speed reducer is installed onto the gripper. The reducer is factory lubricated for the rated life of the gripper. The motor speed reducer provides a convenient means of matching the output torque and shaft speed of many motors to the input requirements of the gripper.

The reducer must be ordered with a motor mounting code. See page 9 for details.

Motor mounting fasteners and motor coupling are supplied unassembled along with assembly instructions.

Use **-W0174** motor mount code to provide the proper interface for use with a PHD-supplied Kollmorgen® motor when option **-M1095** is specified.

Use **-W0000** motor mount code to order a motor mount intended for customer modification. See page 3.

The reducer can be easily removed from the gripper for ease of motor installation and field rotated into one of four positions.

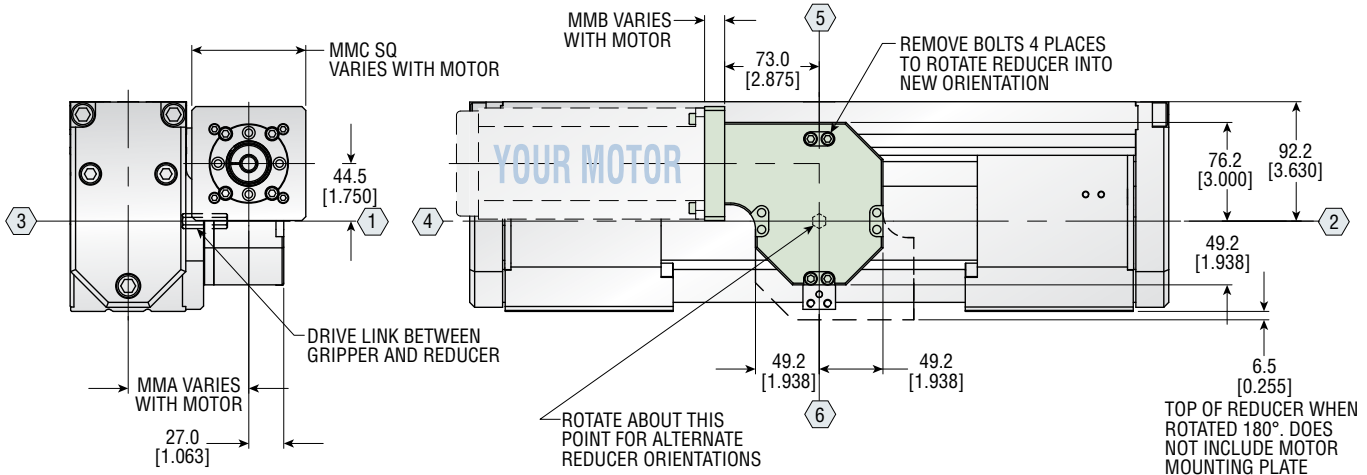
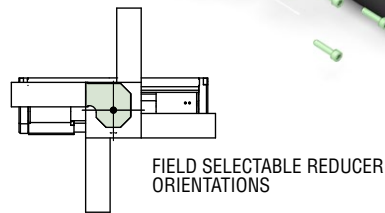
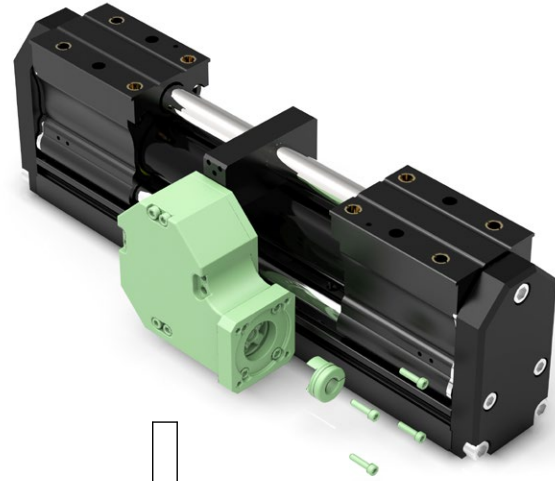

OPTION	MMA				MMB				MMC SQUARE			
	STANDARD		OVERSIZED		STANDARD		OVERSIZED		STANDARD		OVERSIZED	
	mm	in	mm	in	mm	in	mm	in	mm	in	mm	in
W0174	93.6	3.685	—	—	15.5	.610	—	—	70.0	2.756	—	—
Wxxxx*	93.6	3.685	111.6	4.394	11.0 MIN	.433 MIN	11.0 MIN	.433 MIN	88.0	3.465	130	5.118
W0000	93.6	3.685	—	—	22.6	.890	—	—	88.0	3.465	—	—

NOTES:

- 1) ALL DIMENSIONS ARE SHOWN IN mm [in] AND ARE REFERENCE ONLY UNLESS SPECIFICALLY TOLERANCED
- 2) OPTION Wxxxx MUST BE ORDERED WITH OPTION RW151
- 3) REDUCER IS SUPPLIED PREASSEMBLED IN ORIENTATION SHOWN, CUSTOMER MAY ROTATE INTO PREFERRED ORIENTATION AFTER RECEIPT
- 4) WHEN (-W0000) IS SPECIFIED, COUPLER IS SUPPLIED WITH UNFINISHED SHAFT BORE AND MOTOR MOUNTING PLATE IS SUPPLIED WITH DIMENSIONS SHOWN WITHOUT MOTOR MOUNTING FASTENERS
- 5) * Wxxxx CONFIGURED ONLINE

OPTIONS: SERIES EGRR ELECTRIC HIGH CAPACITY GRIPPER

Wxxxx MOTOR MOUNT CODE

phdplus.phdinc.com



Your Motor, Your Way customizable motor mounting is generated by PHD's extensive motor database at www.config.phdinc.com. Users may select their compatible motor of choice from the pre-populated motor database. In the event the chosen motor is not in the database, they may enter necessary motor features to generate the PHD motor mount code.

The tailored motor mounting components are included with the gripper and shipped in kit form. See page 8 for -Wxxxx options and dimensions.

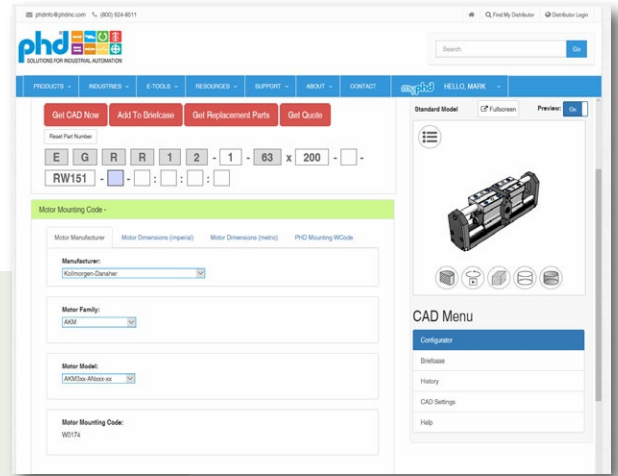

Step 1 - Online Actuator Sizing size.phdinc.com

- Input your application data.
- The sizing software will tell you which gripper and motor performance parameters are needed for your application.

Step 2 - Motor Selection

- Based on the performance requirements determined by online sizing, select an appropriate motor from your preferred motor manufacturer.
- Return to the online sizing software with identified motor parameters to verify motor to application compatibility.

Step 3 - Your Motor, Your Way Configurator config.phdinc.com

- Select your motor from the drop down menus or enter the necessary motor geometry.
- The generated motor mount code for the compatible motor will complete the ordering data necessary to order the gripper tailored to your specific application.
- 3D CAD models are also available.
- If a blank motor mount is desired for special motor requirements, use -W0000 to order a motor mount intended for customer modification.

MOTOR GEOMETRY

NOTES:

- 1) ALL DIMENSIONS ARE REFERENCE ONLY UNLESS SPECIFICALLY TOLERANCED
- 2) MOTOR MOUNT IS SUPPLIED PREASSEMBLED TO MOTOR SPEED REDUCER AND INCLUDES INSTRUCTIONS AND ALL PARTS NECESSARY TO INSTALL MOTOR

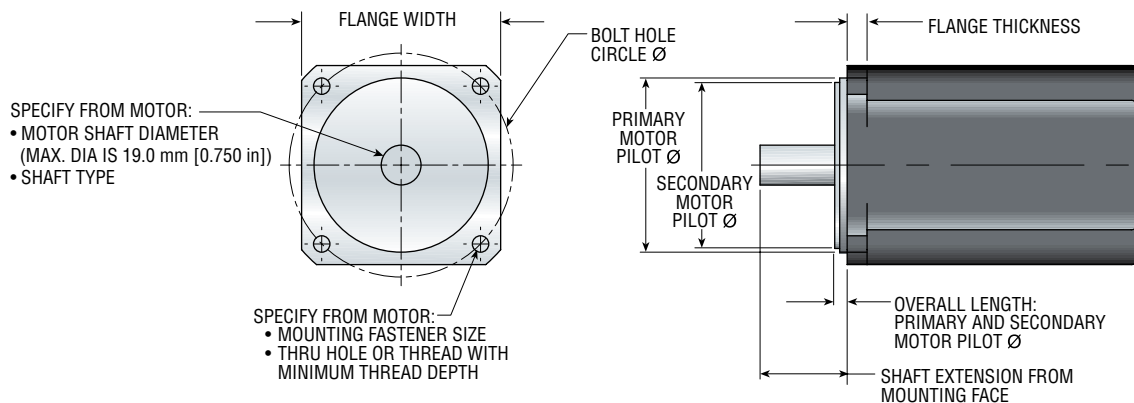

OPTIONS: SERIES EGRR ELECTRIC HIGH CAPACITY GRIPPER

M1095 KOLLMORGEN® MOTOR

Factory-installed Kollmorgen® AKM33H-AN92CA00 motor used with a suitable Kollmorgen® motor controller and RW151 motor speed reducer provides grip forces and jaw speeds comparable to PHD's pneumatic Series GRR Guardian® gripper. This option requires options **-RW151** **-W0174**.

The motor may be field rotated to index location of motor connector.

PERFORMANCE WITH M1095 MOTOR OPTION

MODEL NUMBER	FULL TRAVERSE TIME	MAXIMUM GRIP FORCE*	
	sec	N	lb
EGRR12-x-63 x 150	0.27	3600	809
EGRR12-x-63 x 200	0.34		
EGRR12-x-63 x 250	0.40		
EGRR12-x-63 x 300	0.46		
EGRR12-x-63 x 350	0.53		

*Grip force at zero tooling length

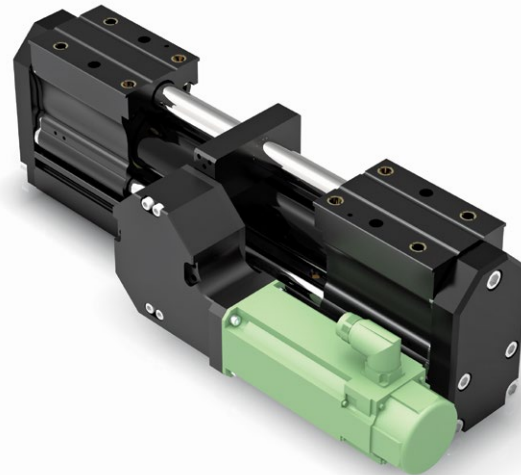

KOLLMORGEN®

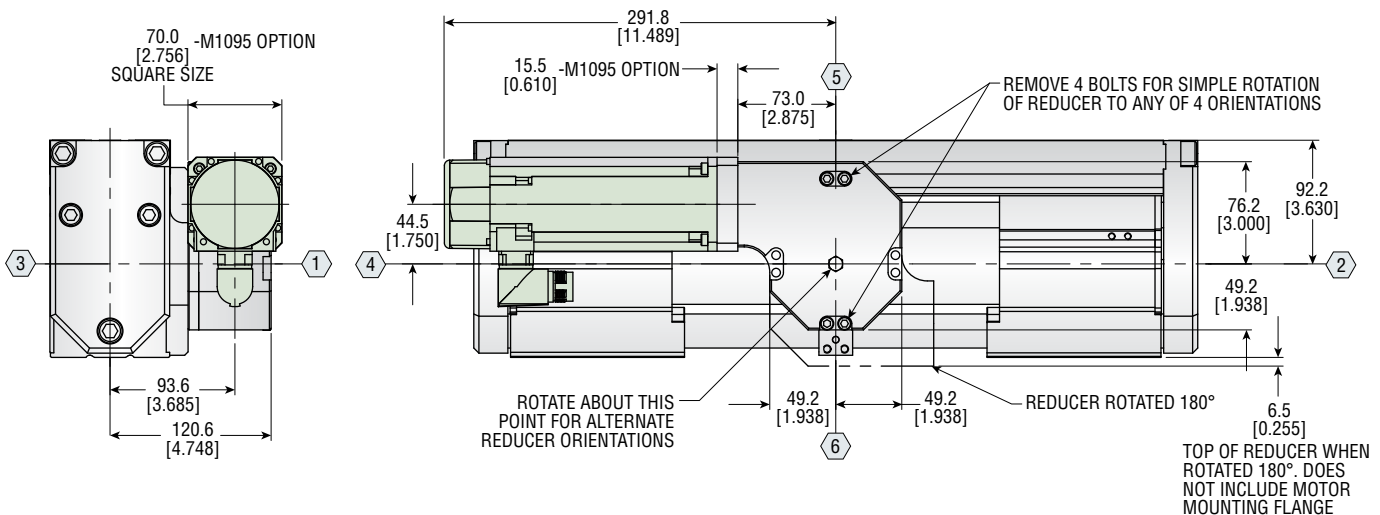

Contact PHD to purchase associated motor drives and cables.

NOTES:

- 1) ALL DIMENSIONS ARE SHOWN IN mm [in] AND ARE REFERENCE ONLY UNLESS SPECIFICALLY TOLERANCED
- 2) MOTOR SPEED REDUCER AND MOTOR ARE SUPPLIED PREASSEMBLED IN ORIENTATIONS SHOWN, CUSTOMER MAY ROTATE INTO PREFERRED ORIENTATIONS AFTER RECEIPT
- 3) WEIGHT OF MOTOR 3.36 kg [7.4 lb] INCLUDING MOTOR BRAKE

ACCESSORIES:

DRIVE LINK

A single drive link couples the output of the motor speed reducer to the input socket of the gripper. The link is intended to mechanically fail reducing catastrophic damage to the gripper and motor speed reducer if maximum torque is exceeded.

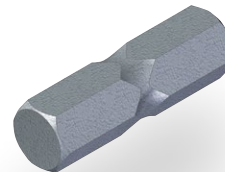

DRIVE LINK KIT

PART NUMBER	DESCRIPTION
88157-0000	Used with Standard Motor Mounting Flange
88157-0018	Used with Oversize Motor Mounting Flange

Kit includes one drive link and installation instructions

ACCESSORIES: SERIES EGRR ELECTRIC HIGH CAPACITY GRIPPER

PROXIMITY SWITCHES - EXTERNAL

This accessory provides for the external mounting of 8 or 12 mm threaded round metal sensing inductive proximity switches. Multiple switches may be mounted using multiple brackets. Proximity switches, targets, and mounting brackets are ordered separately. See the Switches and Sensors section of the main catalog for complete switch specifications.

NOTE: Target and bracket kits do not interchange with Series GRR Grippers Design 1 [5].

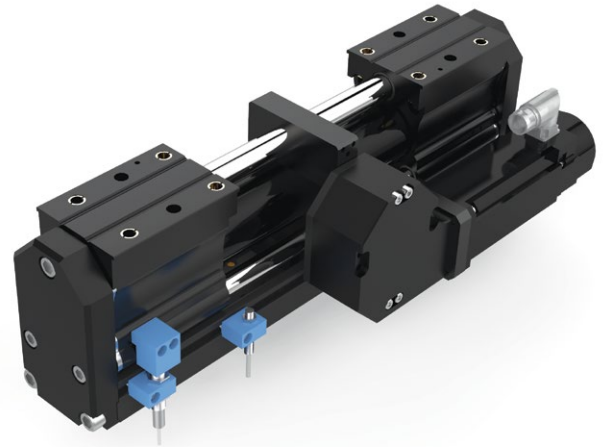

8 mm THREADED INDUCTIVE PROXIMITY SWITCHES

PART NUMBER	DESCRIPTION
51422-005-02	NPN (Sink), 2 meter cable
51422-006-02	PNP (Source), 2 meter cable



8 mm & 12 mm THREADED INDUCTIVE PROXIMITY SWITCH TARGET KIT CORROSION-RESISTANT

74994-33

Kit includes 1 proximity switch target and 2 target mounting screws

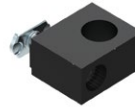

THREADED INDUCTIVE PROXIMITY SWITCH MOUNTING BRACKET KITS

CORROSION-RESISTANT FOR 8 mm SWITCH	CORROSION-RESISTANT FOR 12 mm SWITCH
74992-33	74993-33

Kit includes 1 proximity switch mounting bracket, 1 mounting nut, and 1 mounting screw

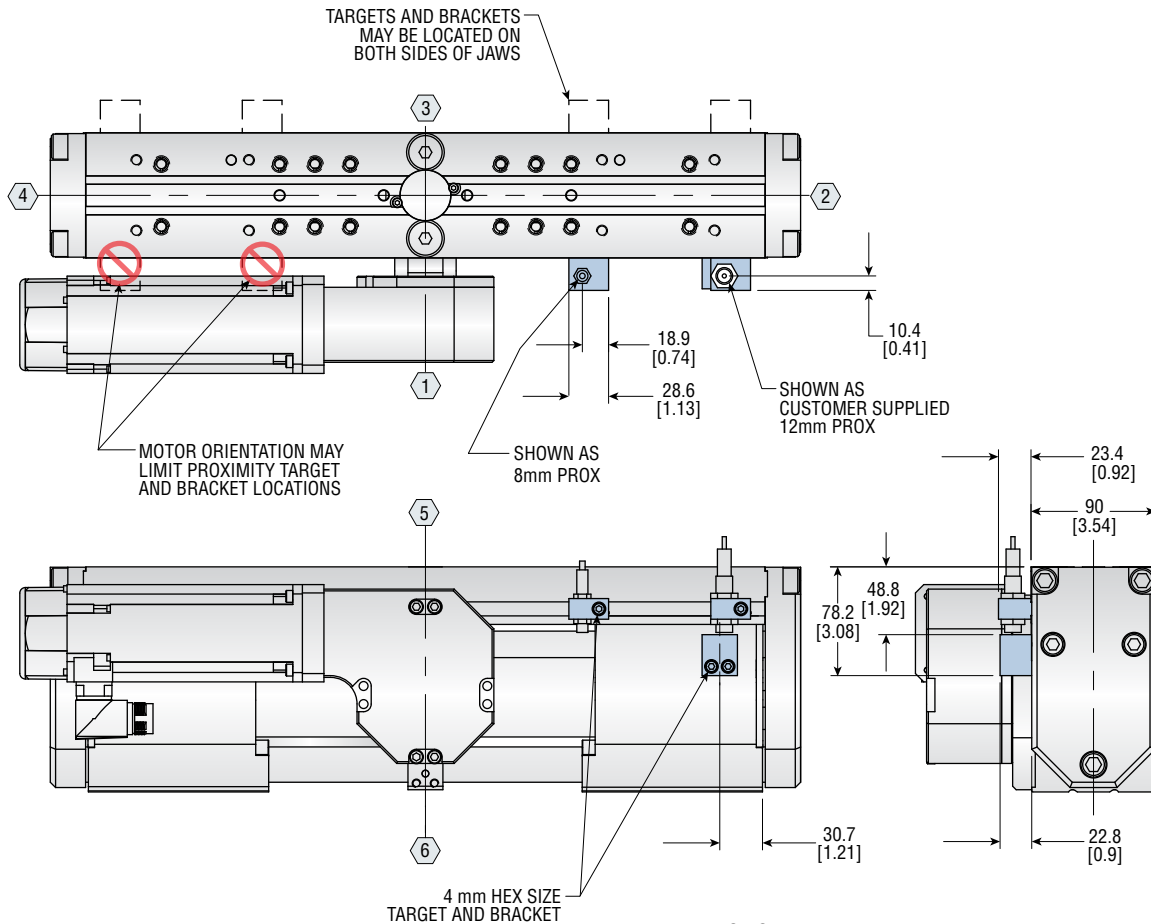

NOTES:

- 1) ALL DIMENSIONS ARE SHOWN IN mm [in] AND ARE REFERENCE ONLY UNLESS SPECIFICALLY TOLERANCED
- 2) DESIGNATED ϕ IS CENTERLINE OF UNIT
- 3) NUMBERS IN \circ INDICATE POSITIONS

ACCESSORIES: SERIES EGRR ELECTRIC HIGH CAPACITY GRIPPER

KOLLMORGEN® MOTOR CONTROLLER AND CABLE ACCESSORIES

(For Series EGRR with options RW151-W0174-M1095 package)

AKD MOTOR CONTROLLER

DESCRIPTION	PHD PART NUMBER	KOLLMORGEN PART NUMBER
AKD Motor Controller 6 Amp 120/240V 1Ph No field bus	87543-P00606-NBAN-00	AKD-P00606-NBAN-0000
AKD Motor Controller 6 Amp 120/240V 1Ph Ethernet/IP	87543-P00606-NBEI-00	AKD-P00606-NBEI-0000
AKD Motor Controller 6 Amp 120/240V 1Ph EtherCAT	87543-P00606-NBEC-00	AKD-P00606-NBEC-0000
AKD Motor Controller 6 Amp 120/240V 1Ph PROFINET	87543-P00606-NBPN-00	AKD-P00606-NBPN-0000

HYBRID SMART FEEDBACK CABLES

DESCRIPTION	PHD PART NUMBER	KOLLMORGEN PART NUMBER
Smart Feedback Hybrid CCJ Series 12 Amp 120/240V 1 meter	88274-1-015-001	CCJ-1A2-015-001-00
Smart Feedback Hybrid CCJ Series 12 Amp 120/240V 3 meter	88274-1-015-003	CCJ-1A2-015-003-00
Smart Feedback Hybrid CCJ Series 12 Amp 120/240V 6 meter	88274-1-015-006	CCJ-1A2-015-006-00
Smart Feedback Hybrid CCJ Series 12 Amp 120/240V 9 meter	88274-1-015-009	CCJ-1A2-015-009-00
Smart Feedback Hybrid CCJ Series 12 Amp 120/240V 12 meter	88274-1-015-012	CCJ-1A2-015-012-00
Smart Feedback Hybrid CCJ Series 12 Amp 120/240V 24 meter	88274-1-015-024	CCJ-1A2-015-024-00

NOTE: Cables are continuous flex rated. For torsional rated cables, please contact PHD applications engineering.

SPECIAL REQUIREMENTS



Capabilities

- Dedicated application assistance
- Fast delivery and competitive pricing
- Separate unique solutions engineering and manufacturing areas dedicated to our customers, ensuring prompt quotes and dependable delivery
- Over 30,000 unique solutions provided and over 100,000 quotes in our database
- Submit your request for a quote and an MDN representative will contact you
- No minimum quantities are required
- CAD files available prior to ordering
- Geared towards short-run requests
- All units receive an “ML” number when ordered. This number, along with all specifications, is kept on permanent record at PHD for future reference and reorders.

www.phdinc.com/unlimited/unique_solutions/

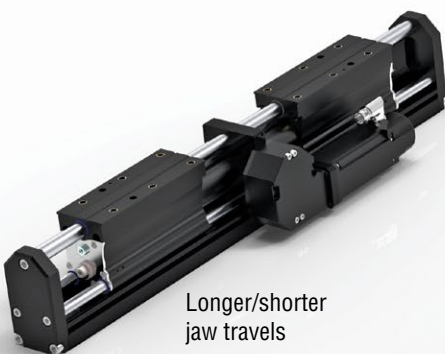

Longer/shorter jaw travels



Non-synchronized jaws/dual travel



Base mounted motor

OTHER UNIQUE POSSIBILITIES

- Alternate reducer gear ratios
- Harsh environment protection
- Alternate motor mounting positions

Renderings are concept only. Contact your local PHD Distributor for more information.