

## GRK

### Major Benefits

- Range of 8 sizes, with grip forces from 86 lb [383 N] up to 2,345 lb [10,431 N] (with spring assist)
- Compact, low profile design provides high grip force and large moment capacities with low overall weight.
- Ultra-rigid, wear-compensating jaw guide system eliminates jaw “free-play” and dramatically reduces jaw deflection when gripping or moving loads over life of unit.
- Convenient switch bundles - one line ordering
- Purge ports standard on 4 larger sizes
- Lubrication reservoirs on 4 larger sizes for extended life
- Rugged construction ensures long operating life.
- Double acting for both internal and external gripping applications.
- Manifold porting capability allows for nested gripper installation.
- Mounting provided from top, bottom, front, and back of gripper for application flexibility.

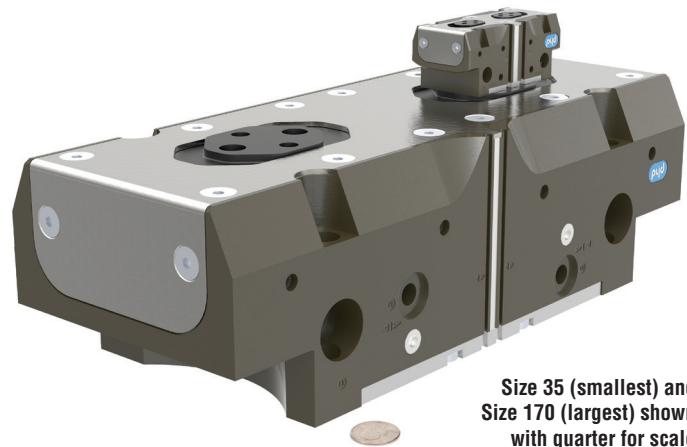

Size 35 (smallest) and Size 170 (largest) shown with quarter for scale

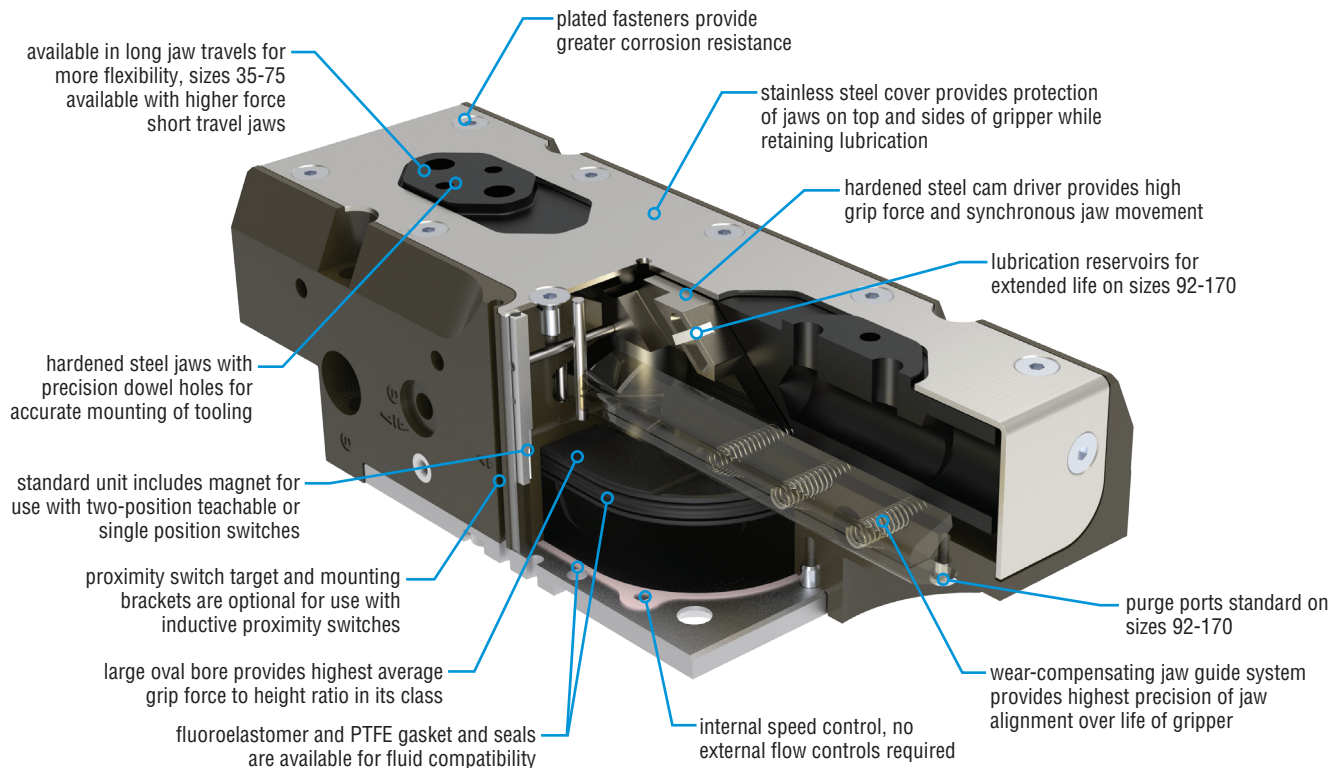

# ORDERING DATA: Series GRK Grippers

## TO ORDER SPECIFY:

Product, Design No., Size, Minimum Total Jaw Travel, and any options required.

**PRODUCT**  
High Precision Parallel Jaw Travel  
High Moment Capacity  
High Grip Force to Height Ratio

**DESIGN NO.\***  
1 - Imperial  
\*\*5 - Metric

**SWITCH SERIES**  
C - Series JC1SDx-x,  
Single Position  
E - Series JC1STP-x,  
Teachable (PNP only)  
P - Inductive Proximity Switch

**SWITCH CIRCUITRY**  
0 - Mounting Hardware Only  
(No Switches)  
N - NPN (Sink)  
P - PNP (Source)

**SWITCH BUNDLE OPTION CODE**  
(see Notes 3-4)

**S x x x x**

**QUANTITY**  
1 or 2 - Inductive Proximity Switches  
or Mounting Brackets  
1 to 9 - JC1SDx-x, JC1DTP-x

**CABLE TYPE**  
0 - No Switches  
K - Quick Connect Only  
(JC1SDx-K, JC1STP-K)  
2 - 2 Meter Length Cable  
(Prox, JC1STP-2)  
5 - 5 Meter Length Cable  
(JC1SDx-5)

**GRK - 1 - 35 x 12 - FSR2 - Sxxxx**

PRODUCT SIZE	BORE SIZE DIAMETER		MINIMUM TOTAL JAW TRAVEL Total Travel Per Bore Size	
	mm	inch	mm	inch
35	35	1.378	6.5	0.256
35	35	1.378	12	0.472
46	46	1.811	8	0.315
46	46	1.811	16	0.630
58	58	2.283	10.5	0.413
58	58	2.283	20	0.787
75	75	2.953	12.5	0.492
75	75	2.953	26	1.024
92**	92	3.622	32	1.260
112**	112	4.409	50	1.969
133**	133	5.236	60	2.362
170**	170	6.693	70	2.756

**OPTIONS**  
(Omit if not required)  
L11-UB99 - Manifold Option in Location 99  
L9 - NPT Ports  
(sizes 92, 112, 133, & 170 only)  
V1 - Fluoroelastomer & PTFE Gaskets  
FSR2 - Spring Assist Close  
FSE2 - Spring Assist Open  
(sizes 35, 46, 58, & 75 only)



Options may affect unit size. See dimensional pages and option information details.

## NOTES:

- \* 1) DESIGN NUMBER DICTATES IMPERIAL OR METRIC MOUNTINGS, DOWEL PIN HOLES, AND PORTS.
- \*\* 2) SIZES 92, 112, 133, & 170 AVAILABLE AS METRIC ONLY. MOUNTINGS AND DOWEL HOLES ARE METRIC. BOTH IMPERIAL AND METRIC PORTS ARE STANDARD ON THESE SIZES. IMPERIAL PORTS ARE PLUGGED STANDARD. L9 OPTION PLUGS METRIC PORTS TO ALLOW USE OF IMPERIAL.
- 3) SWITCH BUNDLE OPTIONS -SP001 AND -SP002 DIRECTLY REPLACE -CB1 AND -CB2 OPTIONS.
- 4) SWITCH BUNDLES AVAILABLE WITH GRIPPER ONLY.

## SERIES JC1ST CORDSET

PART NO.	DESCRIPTION
81284-1-001	M8, 4 pin, Straight Female Connector, 5 m cable

## SERIES JC1SDx CORDSET

PART NO.	DESCRIPTION
63549-02	M8, 3 pin, Straight Female Connector, 2 m cable
63549-05	M8, 3 pin, Straight Female Connector, 5 m cable

# ENGINEERING DATA: Series GRK Grippers

SPECIFICATIONS	IMPERIAL	METRIC
OPERATING PRESSURE STANDARD UNIT SPRING ASSIST UNIT	36 psi min to 120 psi max 66 psi min to 90 psi max	2.5 bar min to 8 bar max 4.5 bar min to 6 bar max
OPERATING TEMPERATURE STANDARD UNIT -V1 OPTION UNIT	-20°F min to +180°F max -20°F min to +250°F max Higher temperature service available. Consult PHD.	-28°C min to +82°C max -28°C min to +121°C max
GRIP REPEATABILITY	±0.0004 in of original position	±0.01 mm of original position
RATED LIFE (with standard seals)	10 million cycles (sizes 35-75), 3 million cycles (sizes 92-170)	
LUBRICATION	Factory lubricated for rated life	

## Application & Sizing Assistance

Use PHD's free online Product Sizing and Application at [www.phdinc.com/apps/sizing](http://www.phdinc.com/apps/sizing)

SIZE	MINIMUM TOTAL JAW TRAVEL		TOTAL CLOSE GRIP FORCE at 87 psi [6 bar]		GRIPPER WEIGHT		DISPLACEMENT ON OPEN		CLOSE OR OPEN TIME at 87 psi [6 bar]	MAX TOOLING LENGTH		GRIP FORCE FACTOR G <sub>F</sub>			
												INTERNAL GRIP		EXTERNAL GRIP	
												Imperial	Metric	Imperial	Metric
35	0.256	6.5	159	707	0.84	0.38	0.35	5.65	0.050	4.00	102	1.92	124	1.83	118
	0.472	12	86	383								1.04	67	1.00	64
46	0.315	8	292	1299	1.52	0.69	0.77	12.65	0.070	5.00	127	3.63	234	3.36	217
	0.630	16	146	649								1.82	117	1.69	109
58	0.413	10.5	454	2019	2.45	1.11	1.52	24.91	0.090	6.38	162	5.63	363	5.23	337
	0.787	20	239	1063								2.96	191	2.75	178
75	0.492	12.5	805	3581	4.33	1.96	3.19	52.19	0.175	7.87	200	9.84	635	9.24	596
	1.024	26	378	1681								4.60	297	4.34	280
92	1.260	32	543	2415	7.8	3.52	6.2	101	0.25	9.85	250	6.48	418	6.24	403
112	1.969	50	821	3652	15.4	6.98	14.3	235	0.38	12.2	310	9.83	634	9.43	608
133	2.362	60	1120	4984	23.9	10.82	23.9	391	0.47	14.0	356	13.58	876	12.88	831
170	2.756	70	1636	7276	42.4	19.23	40.5	663	0.55	14.8	376	19.67	1269	18.80	1213

SIZE	SPRING ASSIST GRIP FORCE								SPRING ASSIST WEIGHT ADDER		CLOSE OR OPEN TIME at 87 psi [6 bar] in sec		
	S <sub>F</sub> (SPRING ONLY)* SPRING CLOSE GRIP FORCE				S <sub>F</sub> (SPRING ONLY)* SPRING OPEN GRIP FORCE								
	MINIMUM		MAXIMUM		MINIMUM		MAXIMUM				WITH SPRING	AGAINST SPRING	SPRING ONLY
	lb	N	lb	N	lb	N	lb	N	lb	kg			
35 x 6.5 FSR2	48	212	61	270	—	—	—	—	0.45	0.20	0.04	0.06	0.13
35 x 6.5 FSE2	—	—	—	—	47	208	59	260					
35 x 12 FSR2	26	115	33	146	—	—	—	—					
35 x 12 FSE2	—	—	—	—	25	113	32	141					
46 x 8 FSR2	88	389	122	543	—	—	—	—	0.76	0.34	0.06	0.08	0.14
46 x 8 FSE2	—	—	—	—	86	382	121	536					
46 x 16 FSR2	44	195	61	272	—	—	—	—					
46 x 16 FSE2	—	—	—	—	43	191	60	269					
58 x 10.5 FSR2	136	606	191	849	—	—	—	—	1.36	0.62	0.07	0.11	0.16
58 x 10.5 FSE2	—	—	—	—	134	597	189	841					
58 x 20 FSR2	72	319	100	446	—	—	—	—					
58 x 20 FSE2	—	—	—	—	70	314	99	442					
75 x 12.5 FSR2	242	1074	341	1518	—	—	—	—	2.47	1.12	0.16	0.20	0.18
75 x 12.5 FSE2	—	—	—	—	237	1056	338	1503					
75 x 26 FSR2	113	504	160	713	—	—	—	—					
75 x 26 FSE2	—	—	—	—	111	496	159	706					
92 x 32 FSR2	163	724	220	977	—	—	—	—	3.7	1.66	0.25	0.44	0.5
112 x 50 FSR2	246	1096	331	1472	—	—	—	—	6.8	3.10	0.39	0.67	0.71
133 x 60 FSR2	336	1495	485	2155	—	—	—	—	10.3	4.69	0.49	0.82	0.8
170 x 70 FSR2	491	2183	709	3155	—	—	—	—	17.9	8.13	0.56	1.02	0.92

\*Spring grip force (S<sub>F</sub>) varies with spring compression. The minimum spring grip force values occur with the spring at least compression (jaws fully closed on spring close units and fully open on spring open units). The maximum spring grip force values occur with the spring at most compression (jaws fully open on spring close units and fully closed on spring open units).

SIZE	AXIAL FORCE		MAXIMUM INDIVIDUAL MOMENTS					
	Fa		Mx		My		Mz	
	lb	N	in-lb	N-m	in-lb	N-m	in-lb	N-m
35	270	1201	880	99	655	74	400	45
46	430	1913	1390	157	1015	115	650	73
58	530	2358	2230	252	1630	184	900	102
75	740	3292	3280	371	2380	269	1280	145
92	1440	6405	5375	607	3735	422	2255	255
112	2140	9519	8535	964	5735	648	3375	381
133	2790	12411	12030	1359	7775	878	4450	503
170	3430	15257	16980	1918	10300	1164	5610	634

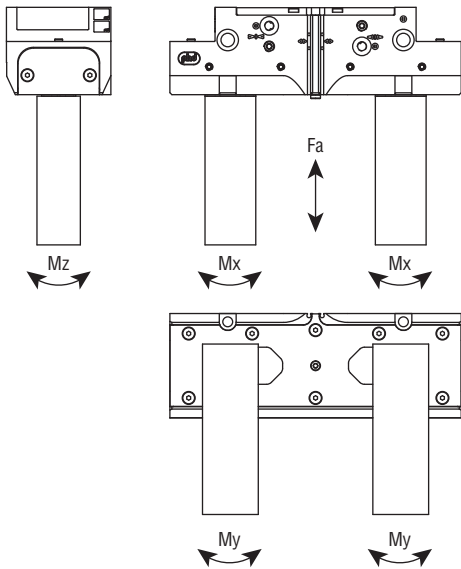

Fa: Total for both jaws

Mx: Maximum allowable moment per jaw, relative to the jaw mounting surface

My: Maximum allowable moment per jaw, relative to the geometric center of the jaw dowel hole pair

Mz: Maximum allowable moment per jaw, relative to the jaw mounting surface

When calculating the value for Fa, include the tooling weight, part weight, external forces, and accelerations. When calculating values for Mx, My, and Mz, include the grip force per jaw, tooling weight, part weight, external forces, and accelerations as applicable.

## RECOMMENDATIONS

Design tooling so that the grip point is as close to the gripper surfaces as possible. The grip force factor (G<sub>F</sub>) values given in the tables on the next two pages are for zero tooling length. As the grip point is moved away from the jaw surface, the applied moment causes jaw friction to increase, resulting in reduced effective grip force. Use the tooling length factor chart below to calculate the effective grip force for a specific grip point.

The maximum load that grippers can handle will vary based on: size of the part being picked up, shape of the part, texture of the part, speed at which the part is transferred, working pressure, shape of the fingers, etc.

## TOOLING LENGTH FACTOR

As the grip point is moved away from the jaw surface, the grip force is reduced due to additional friction generated by the grip induced moment. The tooling length factor allows calculation of the grip force at any grip point. The graph also indicates the maximum tooling length for each gripper size.

## GRIP FORCE CALCULATION EQUATIONS:

### IMPERIAL:

$$\text{Total Grip Force [lb]} = (\text{Pressure [psi]} \times G_F) \times \text{Tooling Length Factor}$$

$$\text{Total Grip Force With Springs [lb]} = ((\text{Pressure [psi]} \times G_F) \pm S_F \text{ [lb]}) \times \text{Tooling Length Factor}$$

### METRIC:

$$\text{Total Grip Force [N]} = (\text{Pressure [bar]} \times G_F) \times \text{Tooling Length Factor}$$

$$\text{Total Grip Force With Springs [N]} = ((\text{Pressure [bar]} \times G_F) \pm S_F \text{ [N]}) \times \text{Tooling Length Factor}$$

SIZES 35, 46, 58, & 75

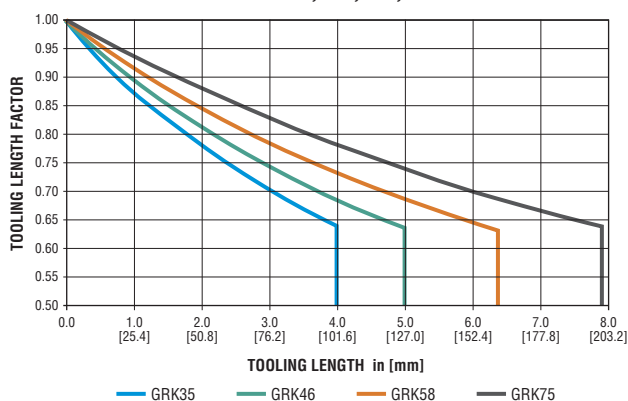

SIZES 92, 112, 133, & 170

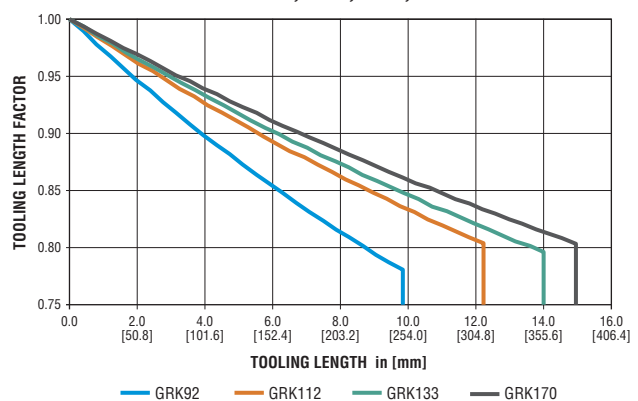

## GRIP FORCE

Total gripping force relative to tooling length is shown below at 87 psi [6 bar] pressure. Grip force per jaw equals the total grip force divided by two. The graphs also indicate the maximum tooling length for each gripper size.

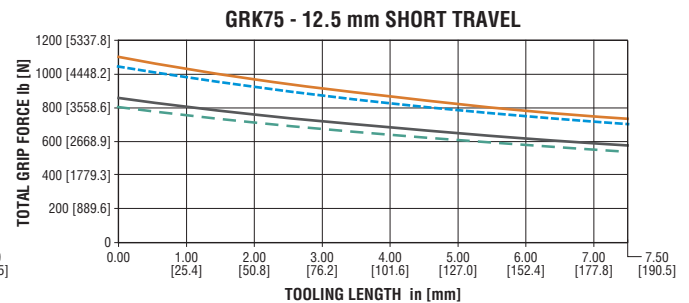
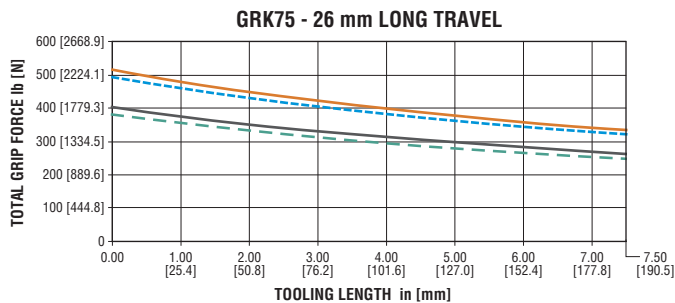
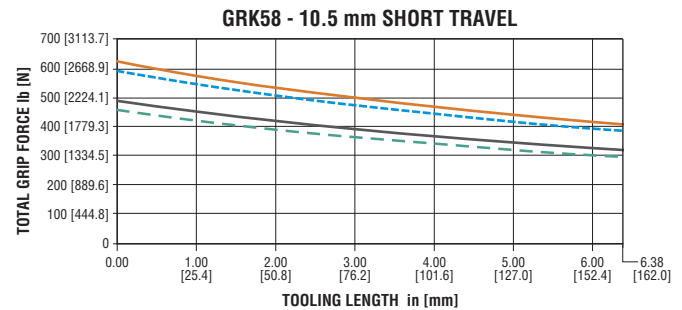
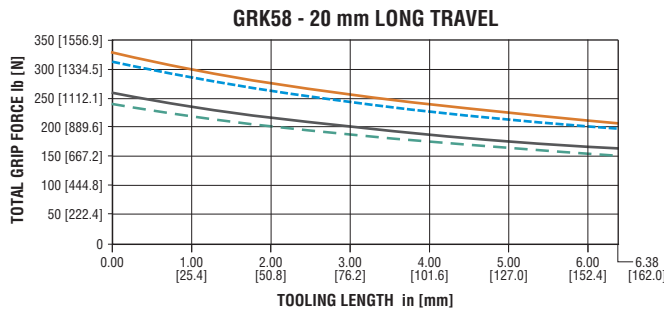
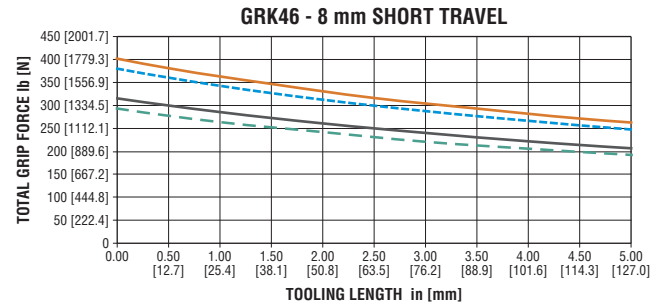
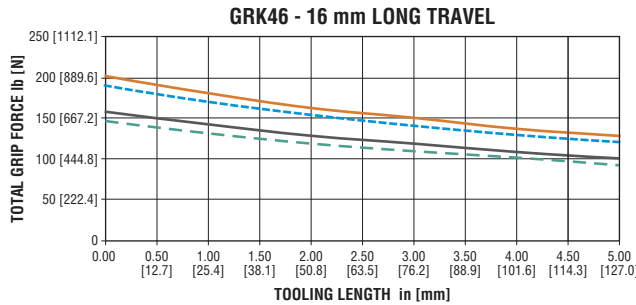
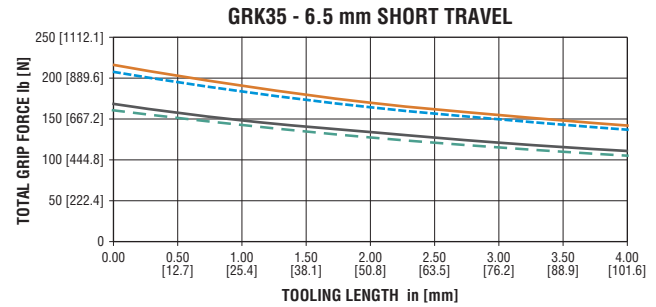
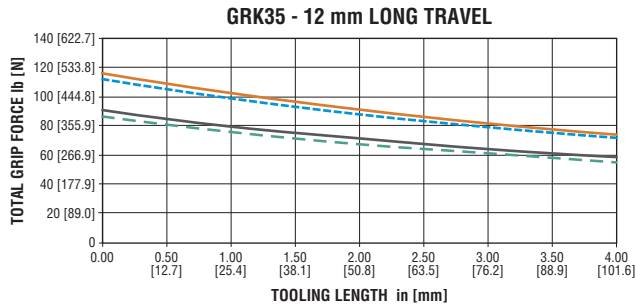
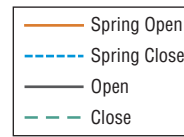

# SIZING: Series GRK Grippers - Sizes 92, 112, 133, 170

NOTE: Spring Open option not available on sizes 92, 112, 133, 170.

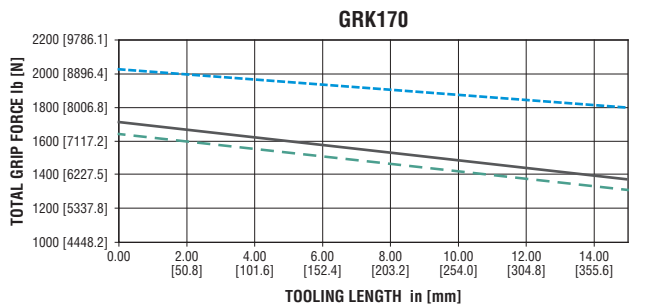
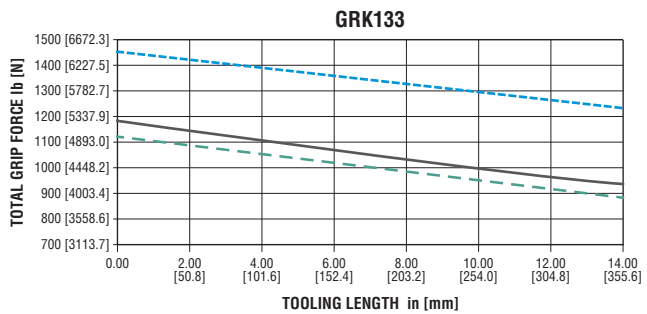
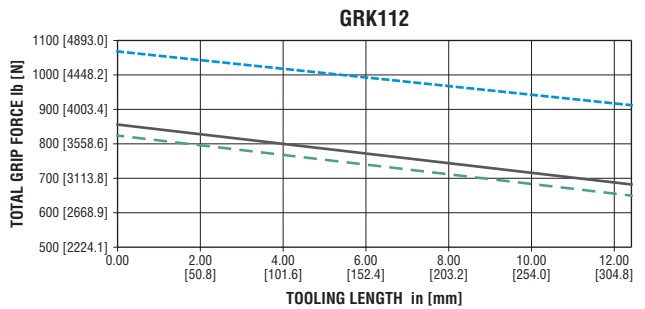
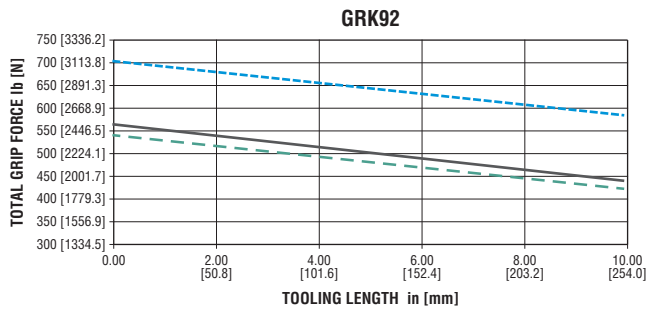
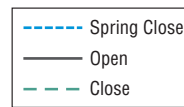

# DIMENSIONS: Series GRK Grippers - Sizes 35, 46, 58, 75

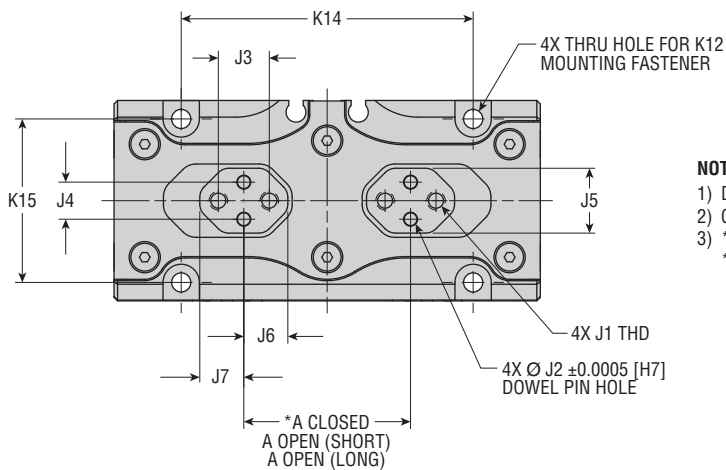
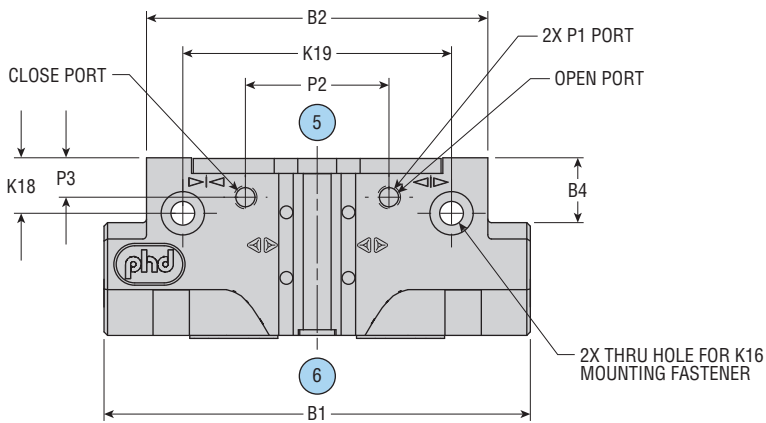
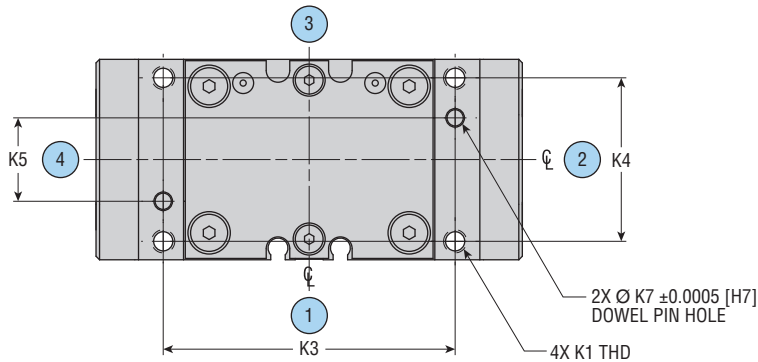
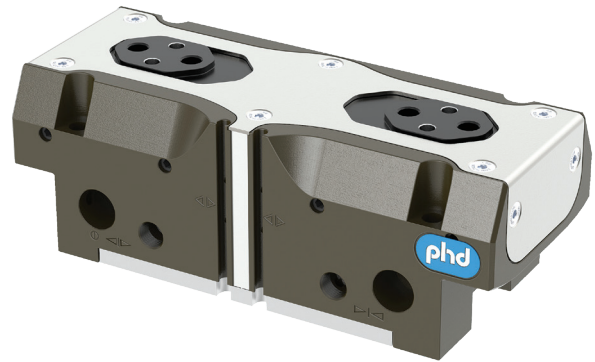
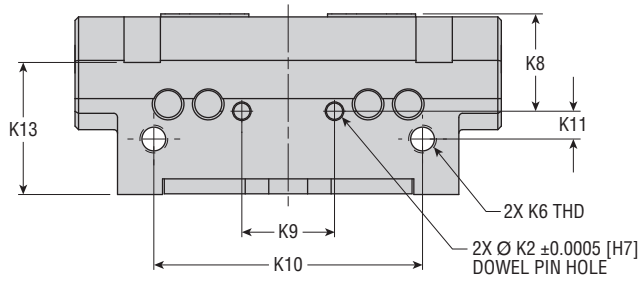

## NOTES:

- 1) DESIGNATED  $\text{CL}$  IS CENTERLINE OF UNIT
- 2) CIRCLED NUMBERS INDICATE POSITIONS
- 3) \*A OPEN REFLECTS SMALLEST POSSIBLE OPEN DIMENSION  
\*A CLOSED REFLECTS LARGEST POSSIBLE CLOSED DIMENSION

All dimensions are reference only unless specifically toleranced.

# DIMENSIONS: Series GRK Grippers - Sizes 35, 46, 58, 75

LETTER DIM	MODEL NUMBER							
	GRK-x-35x6.5 or 12		GRK-x-46x8 or 16		GRK-x-58x10.5 or 20		GRK-x-75x12.5 or 26	
	in	mm	in	mm	in	mm	in	mm
MIN. TRAVEL PER JAW (SHORT)	0.128	3.25	0.158	4.00	0.207	5.25	0.246	6.25
MIN. TRAVEL PER JAW (LONG)	0.236	6.0	0.315	8.0	0.394	10.0	0.512	13.0
A CLOSED*	1.417	36.0	1.732	44.0	2.205	56.0	2.953	75.0
A OPEN SHORT*	1.673	42.5	2.047	52.0	2.618	66.5	3.445	87.5
A OPEN LONG*	1.890	48.0	2.362	60.0	2.992	76.0	3.976	101.0
B1	3.622	92.0	4.456	113.2	5.548	140.9	6.969	177.0
B2	2.900	73.7	3.520	89.4	4.520	114.8	5.640	143.3
B3	1.703	43.3	2.008	51.0	2.362	60.0	2.875	73.0
B4	0.551	14.0	0.720	18.3	0.866	22.0	0.980	24.9
B5	1.509	38.3	1.899	48.2	2.136	54.3	2.450	62.2
J1	8-32 x 0.236 DP	M4 x 0.7 x 6.0 DP	10-32 x 0.295 DP	M5 x 0.8 x 7.5 DP	1/4-28 x 0.295 DP	M6 x 1.0 x 7.5 DP	5/16-24 x 0.394 DP	M8 x 1.25 x 10.0 DP
J2	0.1259 x 0.125 DP	3.0 x 3.1 DP	0.1571 x 0.158 DP	4.0 x 4.0 DP	0.1571 x 0.158 DP	4.0 x 4.0 DP	0.1884 x 0.197 DP	5.0 x 5.0 DP
J3	0.433	11.0	0.551	14.0	0.709	18.0	0.827	21.0
J4	0.3150	8.0	0.3937	10.0	0.4724	12.0	0.5906	15.0
J5	0.551	14.0	0.669	17.0	0.748	19.0	0.984	25.0
J6	0.374	9.5	0.451	11.5	0.569	14.5	0.689	17.5
J7 SHORT	0.472	12.0	0.593	15.1	0.750	19.1	0.945	24.0
J7 LONG	0.374	9.5	0.455	11.6	0.573	14.6	0.689	17.5
J8	1.535	39.0	1.930	49.0	2.165	55.0	2.481	63.0
K1	10-32 x 0.394 DP	M5 x 0.8 x 10.0 DP	1/4-20 x 0.500 DP	M6 x 1.0 x 12.7 DP	5/16-18 x 0.630 DP	M8 x 1.25 x 16.0 DP	5/16-18 x 0.630 DP	M8 x 1.25 x 16.0 DP
K2	0.1571 x 0.197 DP	4.0 x 5.0 DP	0.1884 x 0.197 DP	5.0 x 5.0 DP	0.2509 x 0.25 DP	6.0 x 6.3 DP	0.2509 x 0.250 DP	6.0 x 6.3 DP
K3	2.4803	63.0	3.1496	80.0	4.0160	102.0	5.1181	130.0
K4	1.389	35.3	1.673	42.5	1.890	48.0	2.401	61.0
K5	0.7087	18.0	0.9843	25.0	0.9843	25.0	1.5748	40.0
K6	1/4-20 x 0.500 DP	M6 x 1.0 x 12.7 DP	5/16-18 x 0.630 DP	M8 x 1.25 x 16.0 DP	5/16-18 x 0.630 DP	M8 x 1.25 x 16.0 DP	3/8-16 x 0.787 DP	M10 x 1.5 x 20.0 DP
K7	0.1571 x 0.197 DP	4.0 x 5.0 DP	0.1884 x 0.197 DP	5.0 x 5.0 DP	0.2509 x 0.25 DP	6.0 x 6.3 DP	0.2509 x 0.250 DP	6.0 x 6.3 DP
K8	0.827	21.0	1.064	27.0	1.063	27.0	1.221	31.0
K9	0.7874	20.0	1.1811	30.0	1.3780	35.0	1.9685	50.0
K10	2.283	58.0	2.677	68.0	3.425	87.0	4.331	110.0
K11	0.236	6.0	0.275	7.0	0.374	9.5	0.473	12.0
K12	#8	M4	#10	M5	1/4	M6	1/4	M6
K13	1.122	28.5	1.398	35.5	1.634	41.5	1.791	45.5
K14	2.480	63.0	3.150	80.0	4.016	102.0	5.118	130.0
K15	1.389	35.3	1.673	42.5	1.890	48.0	2.401	61.0
K16	#10	M5	1/4	M6	1/4	M6	5/16	M8
K17	1.423	36.1	1.688	42.9	1.850	47.0	2.285	58.0
K18	0.472	12.0	0.591	15.0	0.728	18.5	0.787	20.0
K19	2.283	58.0	2.677	68.0	3.425	87.0	4.331	110.0
P1	10-32	M5 x 0.8	10-32	M5 x 0.8	1/8 NPT	1/8 BSPP	1/8 NPT	1/8 BSPP
P2	1.220	31.0	1.299	33.0	2.165	55.0	2.677	68.0
P3	0.335	8.5	0.394	10.0	0.531	13.5	0.630	16.0

## CAD & Sizing Assistance

Use PHD's free online Product Sizing and CAD Configurator at [phdinc.com/myphd](http://phdinc.com/myphd)

All dimensions are reference only unless specifically tolerated.

# DIMENSIONS: Series GRK Grippers - Sizes 92, 112, 133, 170

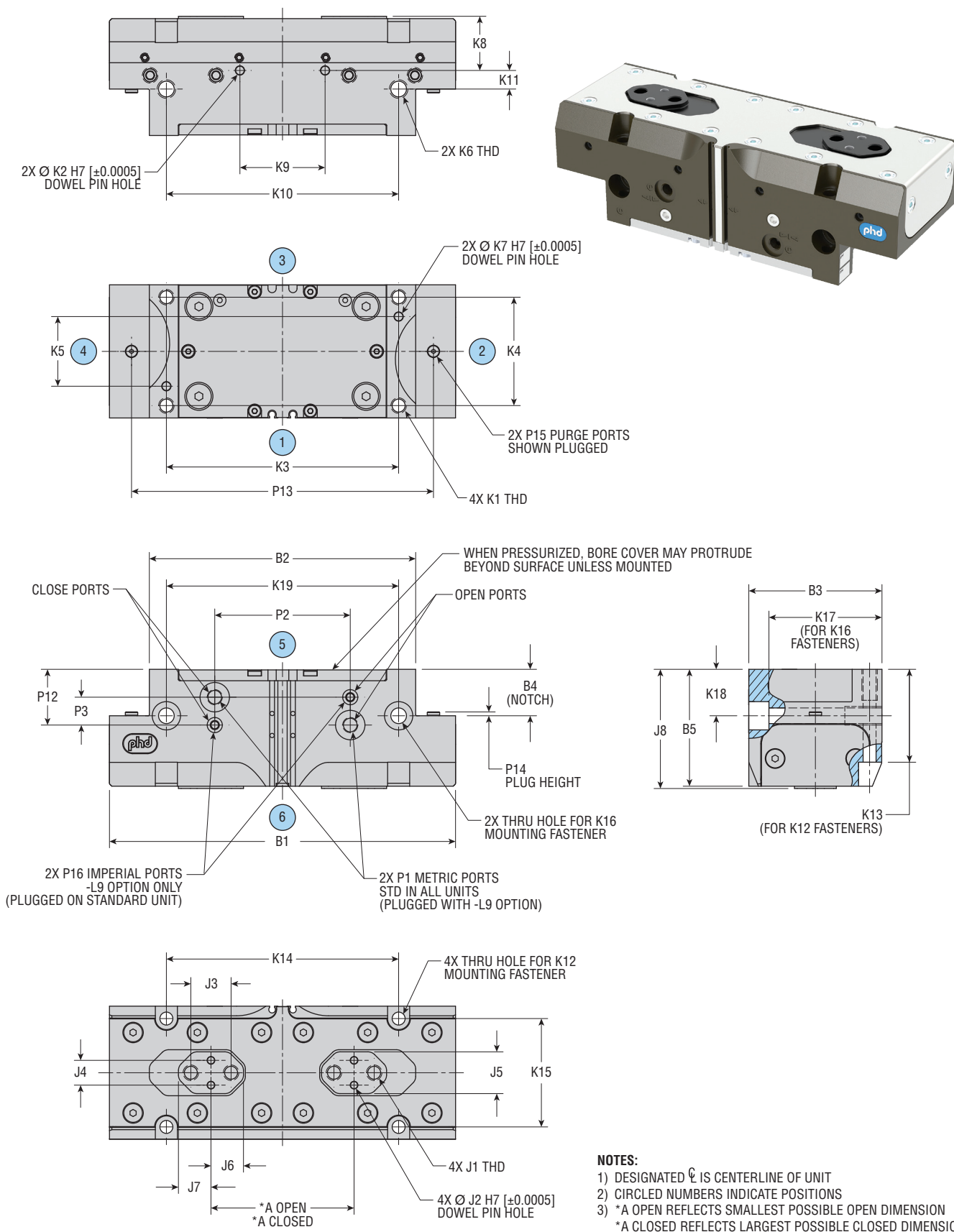

All dimensions are reference only unless specifically toleranced.

# DIMENSIONS: Series GRK Grippers - Sizes 92, 112, 133, 170

LETTER DIM	MODEL NUMBER							
	GRK-5-92x32		GRK-5-112x50		GRK-5-133x60		GRK-5-170x70	
	in	mm	in	mm	in	mm	in	mm
MIN. TRAVEL PER JAW	0.630	16.0	0.984	25.0	1.181	30.0	1.378	35.0
A CLOSED*	3.642	92.5	4.843	123.0	5.354	136.0	6.102	155.0
A OPEN*	4.902	124.5	6.811	173.0	7.717	196.0	8.858	225.0
B1	8.799	223.5	11.752	298.5	13.307	338.0	15.591	396.0
B2	6.772	172.0	8.110	206.0	9.449	240.0	11.417	290.0
B3	3.386	86.0	4.213	107.0	4.921	125.0	6.299	160.0
B4	1.181	30.0	1.378	35.0	1.654	42.0	1.614	41.0
B5	2.972	75.5	3.524	89.5	4.154	105.5	4.748	120.6
J1	M10 x 1.5 x 14.0 DP		M12 x 1.75 x 16.0 DP		M12 x 1.75 x 19.0 DP		M16 x 2.0 x 25.0 DP	
J2	5.0 x 5.0 DP		6.0 x 6.3 DP		8.0 x 8.0 DP		10.0 x 10.0 DP	
J3	1.024	26.0	1.260	32.0	1.417	36.0	1.811	46.0
J4	0.6299	16.0	0.7874	20.0	1.0236	26.0	1.3780	35.0
J5	1.063	27.0	1.378	35.0	1.772	45.0	2.165	55.0
J6	0.827	21.0	1.024	26.0	1.083	27.5	1.378	35.0
J7	0.827	21.0	1.024	26.0	1.083	27.5	1.378	35.0
J8	3.031	77.0	3.583	91.0	4.213	107.0	4.803	122.0
K1	M10 x 1.5 x 20.0 DP		M12 x 1.75 x 22.0 DP		M16 x 2.0 x 25.0 DP		M20 x 2.5 x 30.0 DP	
K2	6.0 x 6.3 DP		8.0 x 8.0 DP		10.0 x 10.0 DP		12.0 x 12.7 DP	
K3	5.9055	150.0	7.0866	180.0	8.2677	210.0	9.8425	250.0
K4	2.756	70.0	3.543	90.0	4.055	103.0	5.315	135.0
K5	1.772	45.0	2.362	60.0	2.559	65.0	3.543	90.0
K6	M12 x 1.75 x 24 DP		M16 x 2.0 x 30 DP		M20 x 2.5 x 30 DP		M24 x 3.0 x 36 DP	
K7	6.0 x 6.3 DP		8.0 x 8.0 DP		10.0 x 10.0 DP		12.0 x 12.7 DP	
K8	1.378	35.0	1.575	40.0	1.969	50.0	2.362	60.0
K9	2.1654	55.0	2.3622	60.0	2.7559	70.0	3.1496	80.0
K10	5.906	150.0	7.087	180.0	8.268	210.0	9.843	250.0
K11	0.472	12.0	0.689	17.5	0.787	20.0	0.669	17.0
K12	M8		M10		M12		M16	
K13	2.362	60.0	2.756	70.0	3.150	80.0	3.543	90.0
K14	5.906	150.0	7.087	180.0	8.268	210.0	9.843	250.0
K15	2.756	70.0	3.543	90.0	4.055	103.0	5.315	135.0
K16	M10		M12		M16		M20	
K17	2.874	73.0	3.543	90.0	4.134	105.0	5.394	137.0
K18	1.181	30.0	1.319	33.5	1.457	37.0	1.772	45.0
K19	5.906	150.0	7.087	180.0	8.268	210.0	9.843	250.0
P1	1/8 BSPP		1/8 BSPP		1/8 BSPP		1/4 BSPP x 10.0 DP (SHORT PER DIN 3852)	
P2	3.445	87.5	3.740	95.0	4.409	112.0	5.512	140.0
P3	0.709	18.0	0.748	19.0	0.768	19.5	0.906	23.0
P12	1.417	36	1.575	40	1.772	45	1.890	48
P13	7.677	195.0	10.039	255.0	11.220	285.0	13.386	340.0
P14	0.098	2.5	0.098	2.5	0.098	2.5	0.098	2.5
P15	M5 x 0.8 x 6.0 DP		M5 x 0.8 x 6.0 DP		M5 x 0.8 x 6.0 DP		M5 x 0.8 x 6.0 DP	
P16	1/8-27 NPT		1/8-27 NPT		1/8-27 NPT		1/4-18 NPT	

## CAD & Sizing Assistance

Use PHD's free online Product Sizing and CAD Configurator at [phdinc.com/myphd](http://phdinc.com/myphd)

All dimensions are reference only unless specifically toleranced.

## FSR2

### SPRING ASSIST CLOSE (ALL SIZES)

## FSE2

### SPRING ASSIST OPEN (SIZES 35, 46, 58, 75 ONLY)

The spring assist option maintains a minimum gripping force if air pressure is reduced or lost. The FSR2 option acts as a closing force, and the FSE2 option acts as an opening force. The spring assist option also provides single acting actuation of the gripper and increases grip force in a specific direction when used with air pressure. Working pressure for spring assist units is 66 psi min. to 90 psi max. [4.6 bar min. to 6.2 bar max.]. For spring grip forces, see table on page 70.

#### Major Benefits

The GRK spring assist option provides all the benefits of the standard GRK with the following additional benefits:

- Provides a mechanical method to retain part in case of pressure loss.
- Increases gripping force.
- Provide single acting gripping actuation.

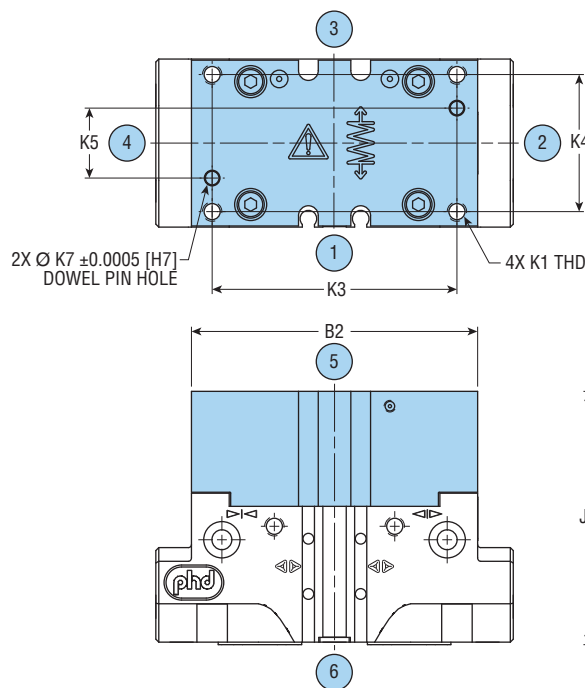
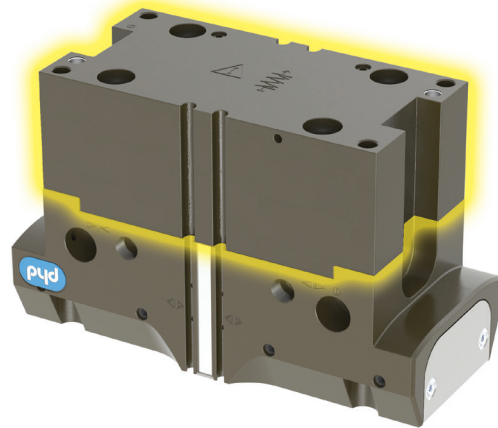

**WARNING:**  
Do not remove spring housing mounting screws.

LETTER DIM	MODEL NUMBER															
	GRK-x-35		GRK-x-46		GRK-x-58		GRK-x-75		GRK-5-92		GRK-5-112		GRK-5-133		GRK-5-170	
	in	mm	in	mm	in	mm	in	mm	in	mm	in	mm	in	mm	in	mm
B2	2.900	73.7	3.520	89.4	4.520	114.8	5.640	143.3	6.772	172.0	8.110	206.0	9.449	240.0	11.417	290.0
B3	1.703	43.3	2.008	51.0	2.362	60.0	2.875	73.0	3.386	86.0	4.213	107.0	4.921	125.0	6.299	160.0
B6	1.681	42.7	1.986	50.4	2.340	59.4	2.843	72.2	3.356	85.2	4.183	106.3	4.893	124.3	6.260	159.0
B7	1.012	25.7	1.247	31.7	1.582	40.2	1.915	48.6	2.165	55.0	2.657	67.5	2.854	72.5	3.227	82.0
J9	2.547	64.7	3.177	80.7	3.747	95.2	4.396	111.7	5.197	132.0	6.240	158.5	7.067	179.5	8.031	204.0
K1	10-32 x 0.394 DP	M5 x 0.8 x 10.0 DP	1/4-20 x 0.500 DP	M6 x 1.0 x 12.7 DP	5/16-18 x 0.630 DP	M8 x 1.25 x 16.0 DP	5/16-18 x 0.630 DP	M8 x 1.25 x 16.0 DP	M10 x 1.5 x 20.0 DP	M12 x 1.75 x 22.0 DP	M16 x 2.0 x 25.0 DP	M20 x 2.5 x 30.0 DP				
K3	2.4803	63.0	3.1496	80.0	4.0160	102.0	5.1181	130.0	5.906	150.0	7.087	180.0	8.268	210.0	9.843	250.0
K4	1.389	35.3	1.673	42.5	1.890	48.0	2.401	61.0	2.756	70.0	3.543	90.0	4.055	103.0	5.315	135.0
K5	0.7087	18.0	0.9843	25.0	0.9843	25.0	1.5748	40.0	1.772	45.0	2.362	60.0	2.559	65.0	3.543	90.0
K7	0.1571 x 0.197 DP	4.0 x 5.0 DP	0.1884 x 0.197 DP	5.0 x 5.0 DP	0.2509 x 0.25 DP	6.0 x 6.3 DP	0.2509 x 0.250 DP	6.0 x 6.3 DP	6.0 x 6.3 DP	8.0 x 8.0 DP	10.0 x 10 DP	12.0 x 12.7 DP				

#### NOTES:

- 1) CIRCLED NUMBERS INDICATE POSITION.
- 2) METRIC INFORMATION SHOWN IN [ ] OR IN COLUMNS DESIGNATED mm.

All dimensions are reference only unless specifically tolerated.

## L11-UB99

### MANIFOLD PORTS

With this option the gripper is configured for manifold mounting on the indicated mounting face. The standard ports are plugged. O-ring seals are provided for mounting between the gripper and the manifold.

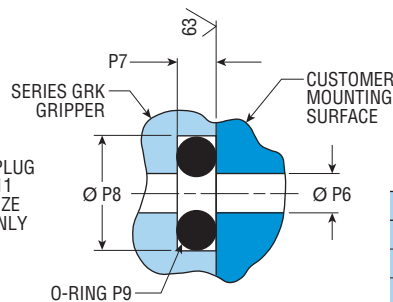
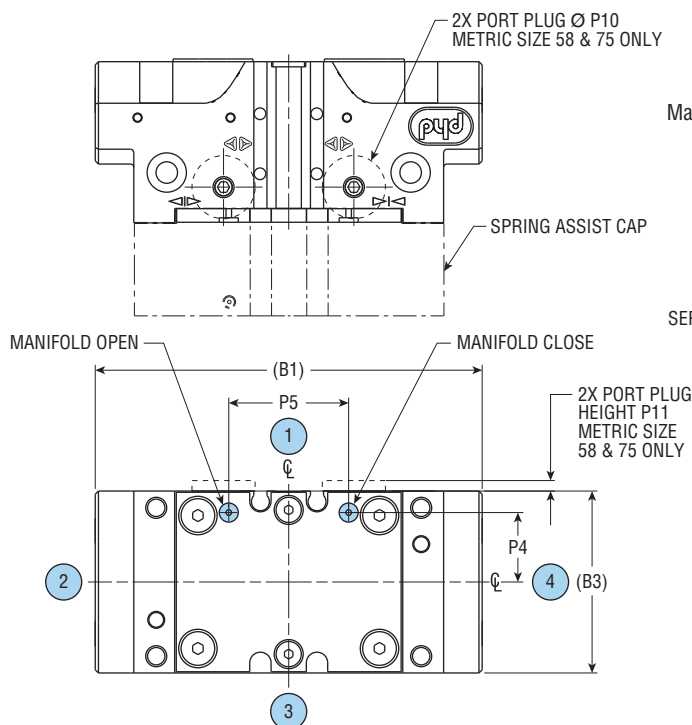
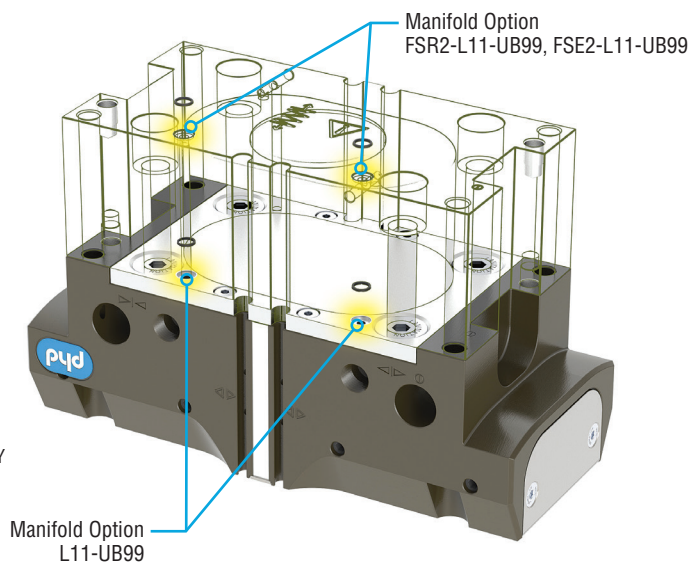

**MANIFOLD PORTING DIMENSIONS**  
For customer use (dimensions required on customer mounting surface)

#### REPLACEMENT MANIFOLD

SIZE	SEAL KIT NUMBER
35	80778-035
46	80778-046
58	80778-058
75	80778-075
92	80778-092
112	80778-112
133	80778-133
170	80778-170

Kit includes 2 replacement o-rings and 1 spare o-ring

LETTER DIM	MODEL NUMBER															
	GRK-x-35		GRK-x-46		GRK-x-58		GRK-x-75		GRK-5-92		GRK-5-112		GRK-5-133		GRK-5-170	
	in	mm	in	mm	in	mm	in	mm	in	mm	in	mm	in	mm	in	mm
P4	0.650	16.5	0.765	19.4	0.837	21.3	1.110	28.2	1.299	33.0	1.673	42.5	1.969	50.0	2.598	66.0
P5	1.122	28.5	1.200	30.5	2.087	53.0	2.480	63.0	3.189	81.0	3.622	92.0	4.173	106.0	5.197	132.0
P6	0.052	1.3	0.064	1.6	0.076	1.9	0.109	2.8	0.126	3.2	0.154	3.9	0.187	4.8	0.250	6.4
P7	0.042	1.1	0.042	1.1	0.042	1.1	0.042	1.1	0.0728	1.85	0.0728	1.85	0.0728	1.85	0.0728	1.85
P8	0.178	4.5	0.216	5.5	0.216	5.5	0.236	6.0	0.315	8.0	0.354	9.0	0.394	10.0	0.433	11.0
P9 O-RING*	1.5 mm x 1.5 mm		2.5 mm x 1.5 mm		2.5 mm x 1.5 mm		3 mm x 1.5 mm		4 mm x 2 mm		5 mm x 2 mm		6 mm x 2 mm		7 mm x 2 mm	
P10	—	—	—	—	0.591	15.0	0.591	15.0	—	—	—	—	—	—	—	—
P11	—	—	—	—	0.098	2.5	0.098	2.5	—	—	—	—	—	—	—	—
(B1)	3.622	92.0	4.456	113.2	5.548	140.9	6.969	177.0	8.799	223.5	11.752	298.5	13.307	338.0	15.591	396.0
(B3)	1.703	43.3	2.008	51.0	2.362	60.0	2.875	73.0	3.386	86.0	4.213	107.0	4.921	125.0	6.299	160.0

**NOTES:**

- DESIGNATED  $\varnothing$  IS CENTERLINE OF UNIT
- CIRCLED NUMBERS INDICATE POSITIONS
- \*I.D. x CROSS-SECTION
- METRIC INFORMATION SHOWN IN [ ] OR IN COLUMNS DESIGNATED mm.

All dimensions are reference only unless specifically tolerated.

## V1

### FLUOROELASTOMER SEALS, PTFE SEALS & GASKETS

Fluoroelastomer seals, PTFE gaskets and spring plugs, and PTFE-based lubricants are available to achieve increased performance with certain fluids and higher temperature applications. Seal compatibility should be checked with the fluid manufacturer for proper application.

Temperature range for -V1 is -20°F min to +250°F max [-28°C min to +121°C max]. Higher temperature service available. Consult PHD.

**NOTE:** Fluoroelastomer seals may not achieve the rated life expectancy as the standard nitrile seals.

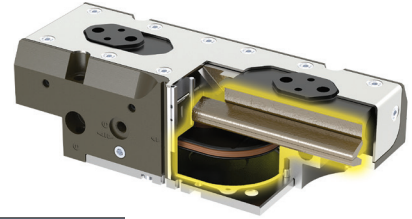

SWITCH TYPE	MAX OPERATING TEMPERATURE
JC1SD	176°F [80°C]
JC1STP Teachable	167°F [75°C]
Inductive Proximity	167°F [75°C]

## L9

### METRIC UNIT WITH IMPERIAL (NPT) PORTS (SIZES 92, 112, 133, 170 ONLY)

Option provides NPT ports by removing standard port plugs. Standard metric BSPP ports are plugged. Does not impact mounting threads or manifolds.

See dimensions on pages 74 and 75 for NPT port locations. Does not apply to sizes 35, 46, 58, or 75.

LETTER DIM	MODEL NUMBER							
	GRK-5-92		GRK-5-112		GRK-5-133		GRK-5-170	
	in	mm	in	mm	in	mm	in	mm
B7	2.2	55.0	2.7	67.5	2.9	72.5	3.2	82.0
P2	3.445	87.5	3.740	95.0	4.409	112.0	5.512	140.0
P3	0.709	18.0	0.748	19.0	0.768	19.5	0.906	23.0
P12	1.417	36	1.575	40	1.772	45	1.890	48
P16	1/8-27 NPT		1/8-27 NPT		1/8-27 NPT		1/4-18 NPT	

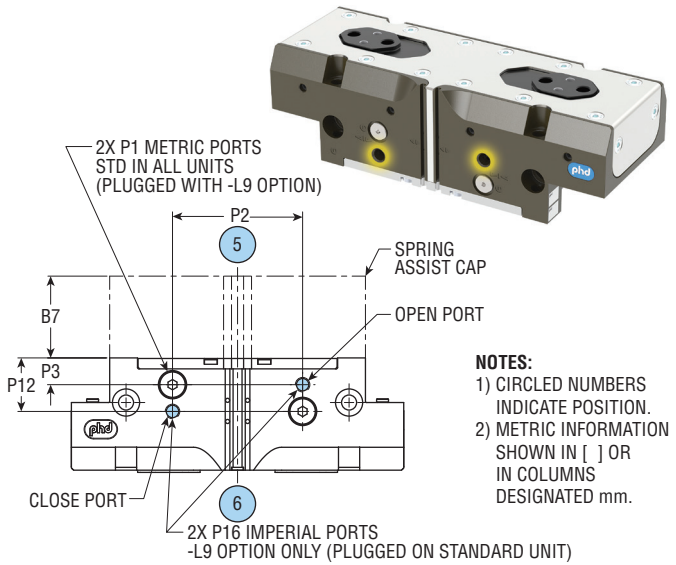

## Sxxxx

### BUNDLED SWITCH OPTIONS

**SP001 replaces previous -CB1 option**  
**SP002 replaces previous -CB2 option**

These options conveniently provide switches with additional hardware if required. Series JC1SDx-x single position and inductive proximity switches are available as NPN or PNP. Series JC1STP-x teachable switch is available as PNP only. Connection method may also be specified along with quantity of switches, up to nine for Series JC and two for inductive proximity switches.

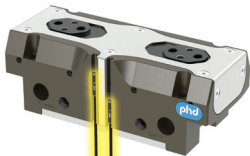
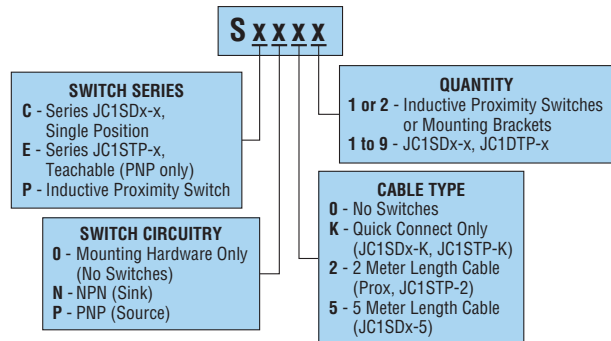

**C** - Series JC1SDx-x Single Position

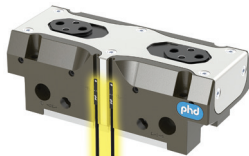

**E** - Series JC1STP-x Teachable (PNP only)

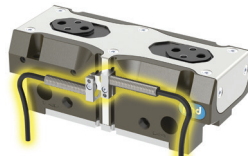

**P** - Inductive Proximity Switch (Includes target, one or two switch mounting brackets, and 8 mm threaded proximity switch, or switches, depending on code.) Target comes assembled in unit.

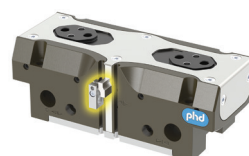

**SP001** - Target with one inductive proximity switch mounting bracket  
 Replaces previous -CB1 option

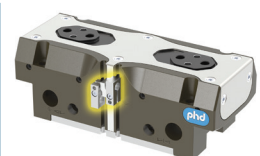

**SP002** - Target with two inductive proximity switch mounting brackets  
 Replaces previous -CB2 option

All dimensions are reference only unless specifically tolerated.

## SERIES JC1SDx-x SINGLE POSITION MAGNETIC SWITCH

This switch provides the ability to identify a single jaw position. Solid-state sensing technology provides a highly reliable switch. Elliptical housing allows for easy “drop-in” installation. Includes LED indicator for convenient means of positioning. Available with PNP or NPN output. Available with cable or 8 mm threaded Quick Connect.

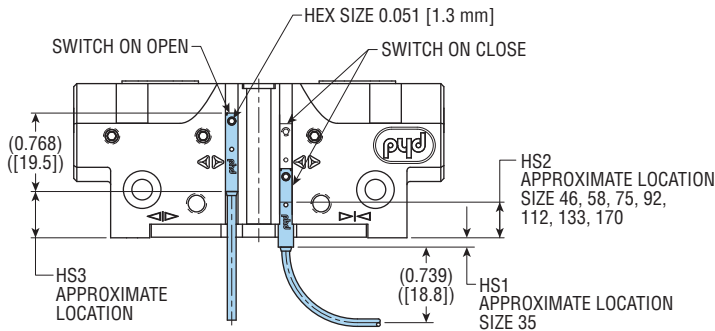
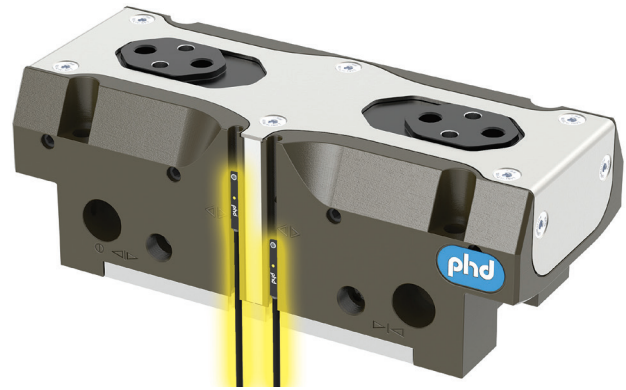

### SERIES JC1SDx SINGLE POSITION SWITCHES

PART NO.	DESCRIPTION
JC1SDN-5	NPN (Sink) Solid State, 10-30 VDC, 5 m cable
JC1SDP-5	PNP (Source) Solid State, 10-30 VDC, 5 m cable
JC1SDN-K	NPN (Sink) Solid State, 10-30 VDC, Quick Connect
JC1SDP-K	PNP (Source) Solid State, 10-30 VDC, Quick Connect

### SERIES JC1SDx CORDSET

PART NO.	DESCRIPTION
63549-02	M8, 3 pin, Straight Female Connector, 2 m cable
63549-05	M8, 3 pin, Straight Female Connector, 5 m cable

LETTER DIM	MODEL NUMBER																
	GRK-x-35		GRK-x-46		GRK-x-58		GRK-x-75		GRK-x-92		GRK-5-112		GRK-5-133		GRK-5-170		
	in	mm	in	mm	in	mm	in	mm	in	mm	in	mm	in	mm	in	mm	
HS1	0.09	2.3	—	—	—	—	—	—	—	—	—	—	—	—	—	—	—
HS2	—	—	0.11	2.8	0.25	6.4	0.27	6.8	0.41	10.3	0.35	8.9	0.43	11.0	0.41	10.5	—
HS3	0.45	11.5	0.73	18.5	0.94	23.9	0.85	21.6	1.30	33.1	1.58	40.2	1.80	45.8	1.87	47.4	—

#### NOTES:

- 1) METRIC INFORMATION SHOWN IN [ ] OR IN COLUMNS DESIGNATED mm.
- 2) SWITCH DIMENSIONS ONLY APPROXIMATE THE INITIAL LOCATION OF THE SENSING ZONES AT FULL OPEN AND CLOSE.

### JC1SDx-5

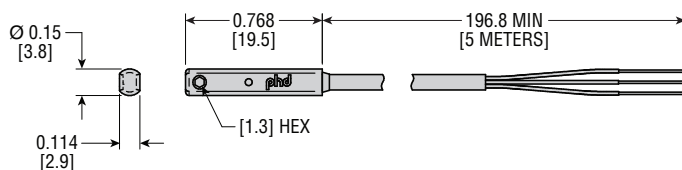

### JC1SDx-K (Quick Connect)

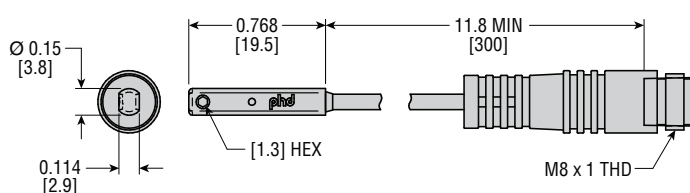

### 63549-xx CORDSET

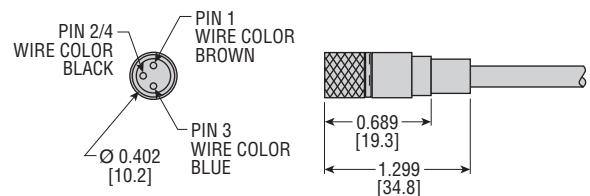

All dimensions are reference only unless specifically tolerated.

## SERIES JC1STP-x TWO POSITION TEACHABLE SWITCHES

This switch provides the ability to identify two separately programmable positions with a single switch. Programmable capability means no “fine-tuning.” With the switch properly aligned, just place the jaws in desired positions and program. Solid-state sensing technology provides a highly reliable switch. Elliptical housing allows for easy “drop-in” installation. Includes LED indicators for convenient means of positioning and programming. Available with cable or 8 mm threaded Quick Connect.

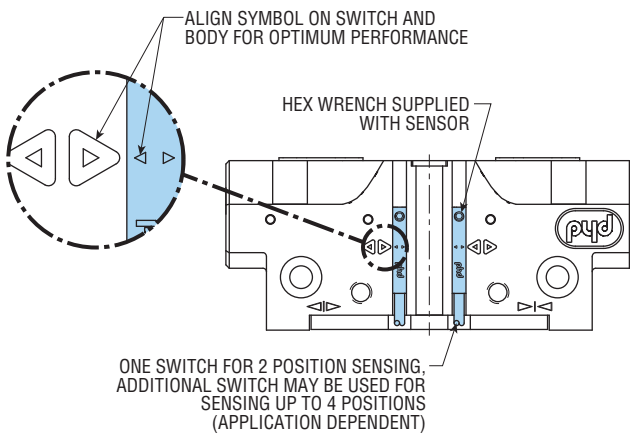

## SERIES JC1ST TWO POSITION TEACHABLE MAGNETIC SWITCHES

PART NO.	DESCRIPTION
JC1STP-2	PNP (Source), Solid State, 12-30 VDC, 2 m cable
JC1STP-K	PNP (Source), Solid State, 12-30 VDC, Quick Connect

Includes one switch and installation directions.

## SERIES JC1ST CORDSET

PART NO.	DESCRIPTION
81284-1-001	M8, 4 pin, Straight Female Connector, 5 m cable

### JC1STP-2

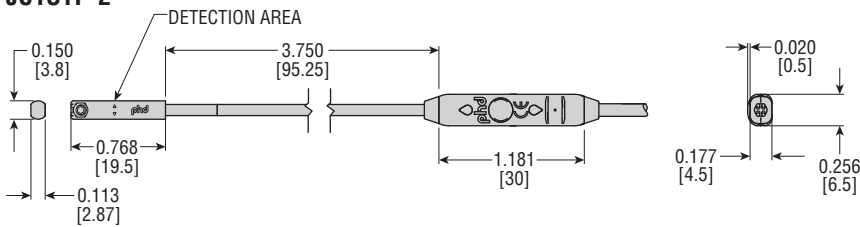

### JC1STP-K (Quick Connect)

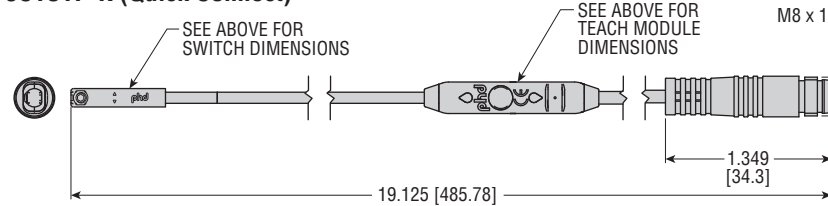

### 81284-1-001 CORDSET

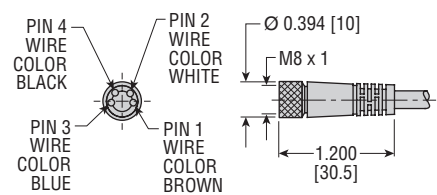

All dimensions are reference only unless specifically tolerated.

## USING SERIES JC1ST TEACHABLE SWITCHES WITH SERIES GRK

The switches perform best when gripping part(s) in the “Optimal Part Detection Range,” which is the middle area of the jaw travel. As the position to be sensed moves nearer to either end of jaw travel (area “B”) the switching point accuracy will decrease.

Once the first position is taught, the jaws must travel a “minimum distance” before the second position can be taught. This minimum distance equals the Minimum Difference in Part Size that can be detected based on total jaw travel. See the Travel Distance chart for these distances as it pertains to the model of GRK gripper you will be using.

**NOTE: Minimum Difference in Part Size can fall anywhere within the Optimal Part Detection Range.**

When one taught position is full open or full closed, then each jaw must travel “B” distance before the next point can be taught.

Use this data in applying the Series JC1ST Teachable Switches in your specific application.

In the event that the positions you need to sense are less than “Minimum Difference in Part Size,” you may need to utilize a JC1ST Teachable and the JC1SD switch combination to achieve your requirements.

The JC1ST Teachable and the JC1SD Switches can be used in combinations for more than two sensing outputs.

For longer travel units: adjusting position of switch towards jaw side of gripper provides better resolution towards open, adjusting switch towards base side of gripper provides better resolution towards close.

### GRK SHORT TRAVEL DISTANCE

SIZE	MINIMUM DIFFERENCE IN PART SIZE		B		TOTAL JAW TRAVEL		OPTIMAL PART DETECTION RANGE	
	in	mm	in	mm	in	mm	in	mm
35	0.050	1.27	0.034	0.86	0.256	6.50	0.120	3.05
46	0.050	1.27	0.035	0.89	0.315	8.00	0.175	4.45
58	0.050	1.27	0.050	1.27	0.413	10.5	0.213	5.41
75	0.050	1.27	0.063	1.60	0.492	12.5	0.240	6.10

### GRK LONG TRAVEL DISTANCE

SIZE	MINIMUM DIFFERENCE IN PART SIZE		B		TOTAL JAW TRAVEL		OPTIMAL PART DETECTION RANGE	
	in	mm	in	mm	in	mm	in	mm
35	0.100	2.54	0.059	1.50	0.472	12.0	0.236	6.00
46	0.100	2.54	0.065	1.65	0.630	16.0	0.370	9.40
58	0.100	2.54	0.090	2.29	0.787	20.0	0.427	10.85
75	0.100	2.54	0.127	3.22	1.024	26.0	0.516	13.11
92	0.157	4.0	0.217	5.50	1.260	32.0	0.315	8.00
112	0.157	4.0	0.217	5.50	1.969	50.0	0.315	8.00
133*	0.197	5.0	0.236	6.00	2.362	60.0	0.433	11.00
170*	0.197	5.0	0.276	7.00	2.756	70.0	0.433	11.00

\*Maximum sensing distance is 50 mm of total jaw travel. Sizes 133 and 170 can exceed the maximum sensing distance.

**NOTE:**  
METRIC INFORMATION SHOWN IN [ ] OR IN COLUMNS DESIGNATED mm.

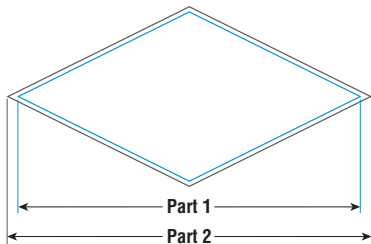

Part 2 – Part 1 = Minimum Difference in Part Size

**NOTE:** The distances in the illustration are exaggerated for visual demonstration.

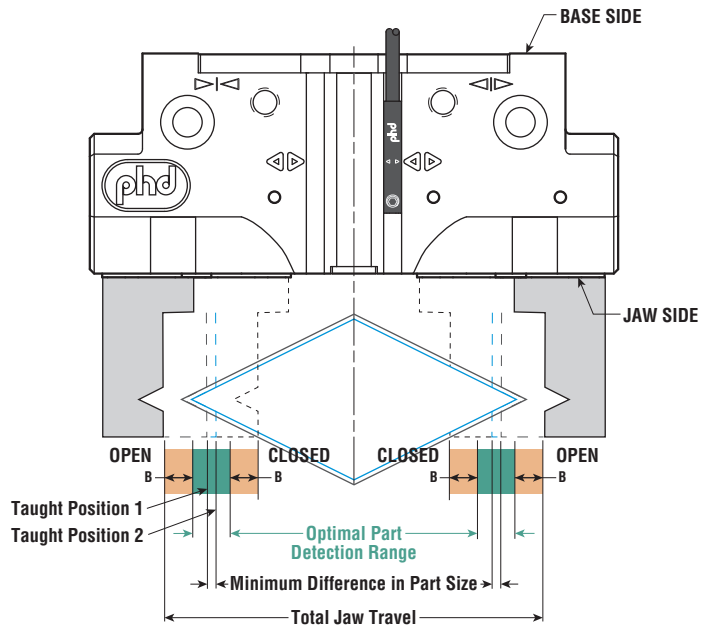

All dimensions are reference only unless specifically tolerated.

## INDUCTIVE PROXIMITY SWITCHES, MOUNTING HARDWARE, AND BRACKETS (-SPxxx OPTION REQUIRED)

This switch provides high reliability by the use of solid state sensing technology. The Series 51422 switch is suitable for plant environments where dirt and contamination create difficulties for electromechanical and other types of switches. Includes LED indicator for convenient means of positioning.

-SPxxx Option (target and mounting bracket/brackets) is required when using inductive proximity switches. For additional switch information, go to [phdinc.com](http://phdinc.com).

### 8 mm THREADED INDUCTIVE PROXIMITY SWITCHES

PART NO.	DESCRIPTION
51422-005-02	NPN (Sink), 10-30 VDC, 2 m cable
51422-006-02	PNP (Source), 10-30 VDC, 2 m cable

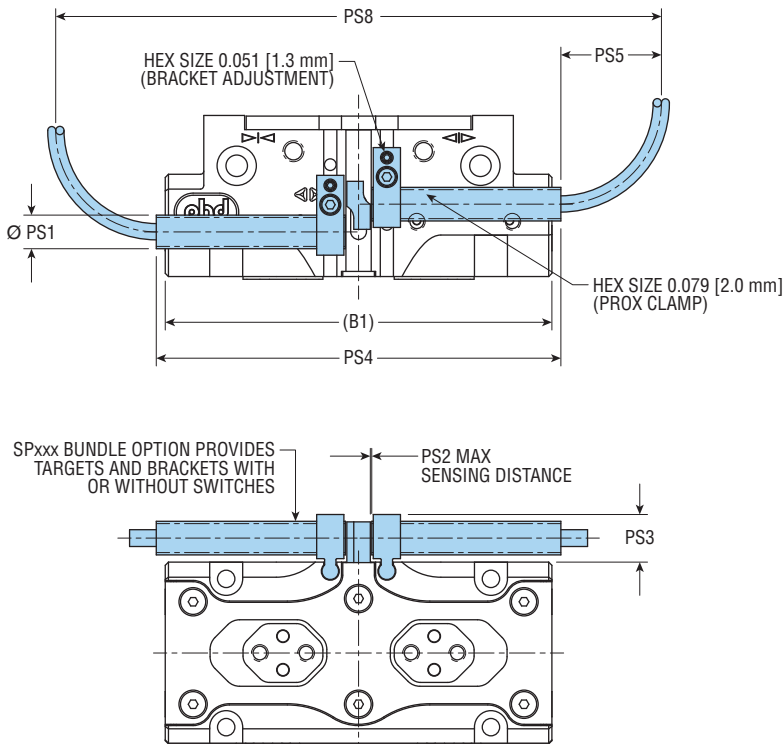

### MOUNTING ORIENTATIONS

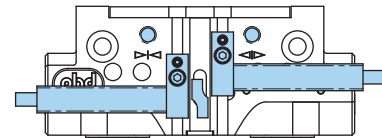

SIZES 35, 46, 58, 75  
PROXIMITY SWITCH MOUNTING LOCATIONS  
ON IMPERIAL AND METRIC UNITS

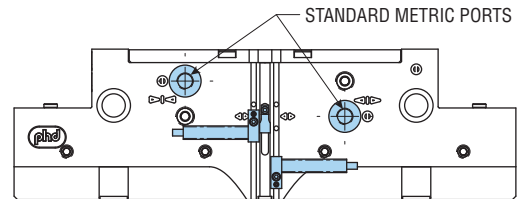

SIZES 92, 112, 133, 170  
PROXIMITY SWITCH BRACKET MOUNTING LOCATIONS  
ON STANDARD UNITS WITH METRIC PORTS

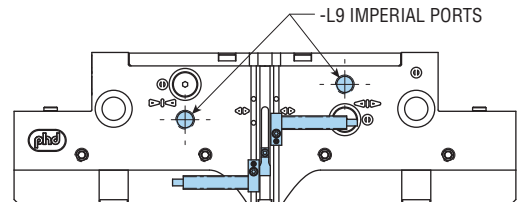

SIZES 92, 112, 133, 170  
WITH -L9 IMPERIAL PORTS  
PROXIMITY SWITCH MOUNTING LOCATIONS

LETTER DIM	MODEL NUMBER															
	GRK-x-35		GRK-x-46		GRK-x-58		GRK-x-75		GRK-5-92		GRK-5-112		GRK-5-133		GRK-5-170	
	in	mm	in	mm	in	mm	in	mm	in	mm	in	mm	in	mm	in	mm
PS1	8 mm THREADED															
PS2	0.030	0.8	0.030	0.8	0.030	0.8	0.030	0.8	0.030	0.8	0.030	0.8	0.030	0.8	0.030	0.8
PS3	0.460	11.7	0.460	11.7	0.460	11.7	0.460	11.7	0.460	11.7	0.460	11.7	0.460	11.7	0.460	11.7
PS4	3.79	96.3	3.79	96.3	3.79	96.3	3.79	96.3	3.79	96.3	3.79	96.3	3.79	96.3	3.79	96.3
PS5	0.95	24.0	0.95	24.0	0.95	24.0	0.95	24.0	0.94	24.0	0.94	24.0	0.94	24.0	0.94	24.0
PS8	5.67	144.1	5.67	144.1	5.67	144.1	5.67	144.1	5.67	144.1	5.67	144.1	5.67	144.1	5.67	144.1
(B1)	3.622	92.0	4.456	113.2	5.548	140.9	6.969	177.0	8.663	223.5	11.752	298.5	13.307	338.0	15.591	396.0

**NOTE:**  
METRIC INFORMATION SHOWN IN [ ] OR IN COLUMNS DESIGNATED mm.

All dimensions are reference only unless specifically tolerated.